

Technical Manual

JBL VT4882



SPECIFICATIONS

ACOUSTIC & ELECTRICAL SPECIFICATIONS:

- Nominal Impedance: 8 ohms, each transducer
- Power Capacity: 4800 W Peak (1200 - 2400 W recommended amplified power)
- Frequency Range: 28 Hz – 120 kHz (–10 dB)
- Maximum SPL: 131 dB SPL peak (1w @ 1m)
- System Sensitivity: 95 dB SPL (1w @ 1m), 35-120Hz

SYSTEM COMPONENTS:

- Cabinet: Enclosure Assembly C4882
- Grille: 352248-001
- Low Frequency Transducer: (2) 2266H (15 in) dia., 76.2 mm (3 in) Dual Coil, Neodymium Differential Drive, Direct Cooled
- DC Resistance: 4.9 ohms ± 10%

AURAL SWEEP TEST SPECIFICATIONS:

- A. System Aural Sweep Test: 10.0V Input, 20 Hz to 1 kHz
- B. L.F. Aural Sweep Test: 10.0V Input, 20 Hz to 1 kHz

PHYSICAL SPECIFICATIONS:

- Enclosure Dimensions: 457 mm x 1013.46 mm x 858.5 mm D (18 in. x 39.9 in. x 133.8 in. D)
- Net Weight: 114.6 lbs. (52 kg.)

WARRANTY INFORMATION:

- Refer to Warranty Statement packed with each product.

PACKAGE

Warranty 59660

Spec Sheet 353407-001

Top and Bottom Filler 353249-001

Pkg Microfoam 49790P

Carton 353248-001

JBL VT4888-AF		
Carton 350484-001	<u>VT4882-ACC</u>	<u>VT4882ADP-ACC</u>
Filler (2) 350486-001	Dolly Assembly 353245-001	Dolly Assembly 353245-001
Owner's Manual 350485-001	Carton 354404-001	Carton 360824-001
JBL VT4888-SF		
Carton 350706-001	Tube, (2) 353462-001	Tube, (2) 360822-001
Filler (2) 350713-001	Insert (2) 353463-001	Insert (2) 353463-001
Owner's Manual 350485-001	Soft Cover 353246-001	Soft Cover 360778-001

WIRING DIAGRAM

Driver (2)
Low Freq
2266H
(353418-001X)
Cone Repl
C8R2266

SCHMATIC

Input Connector
353242-003
Wiring Harness
355079-001

MOLEX 10-PIN CABLE MOUNT

48" RED, 16owg → P1 STRIP & TIN (+)

48" BLK, 16owg → P2 STRIP & TIN (-)

48" GRN, 16owg → P3 STRIP & TIN (+)

48" GRN/BLK, 16owg → P4 STRIP & TIN (-)

Pin Outs NL-4
1± 8 Ohms
2± 8 Ohms
Pin Outs NL-8
1± 8 Ohms
2± 8 Ohms
3± Thru
4± Thru

JBL VT4882

COMPONENT EXPLODED VIEW

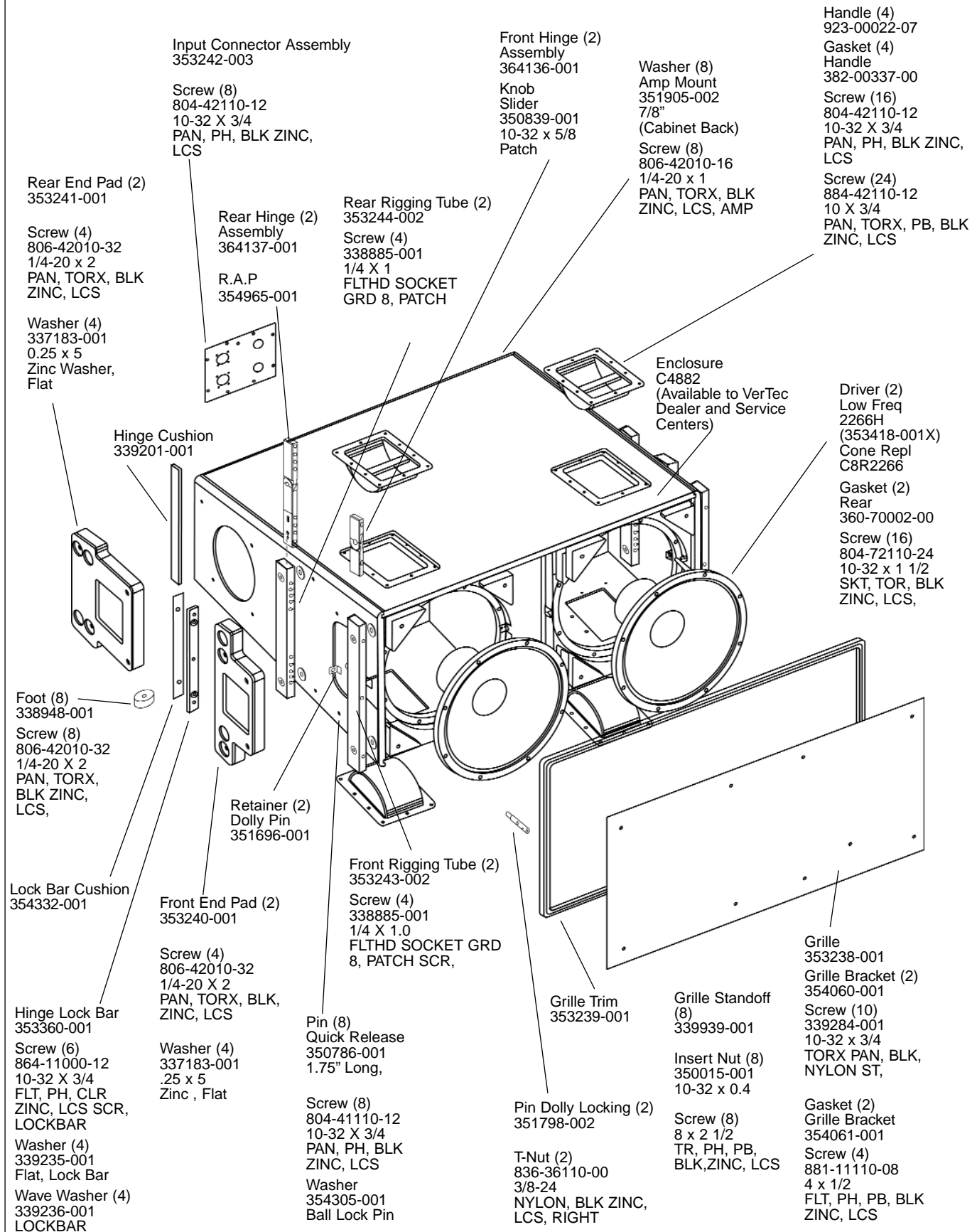

JBL VT4882DP-ACC

REV B

DOLLY ASSEMBLY 353245-001

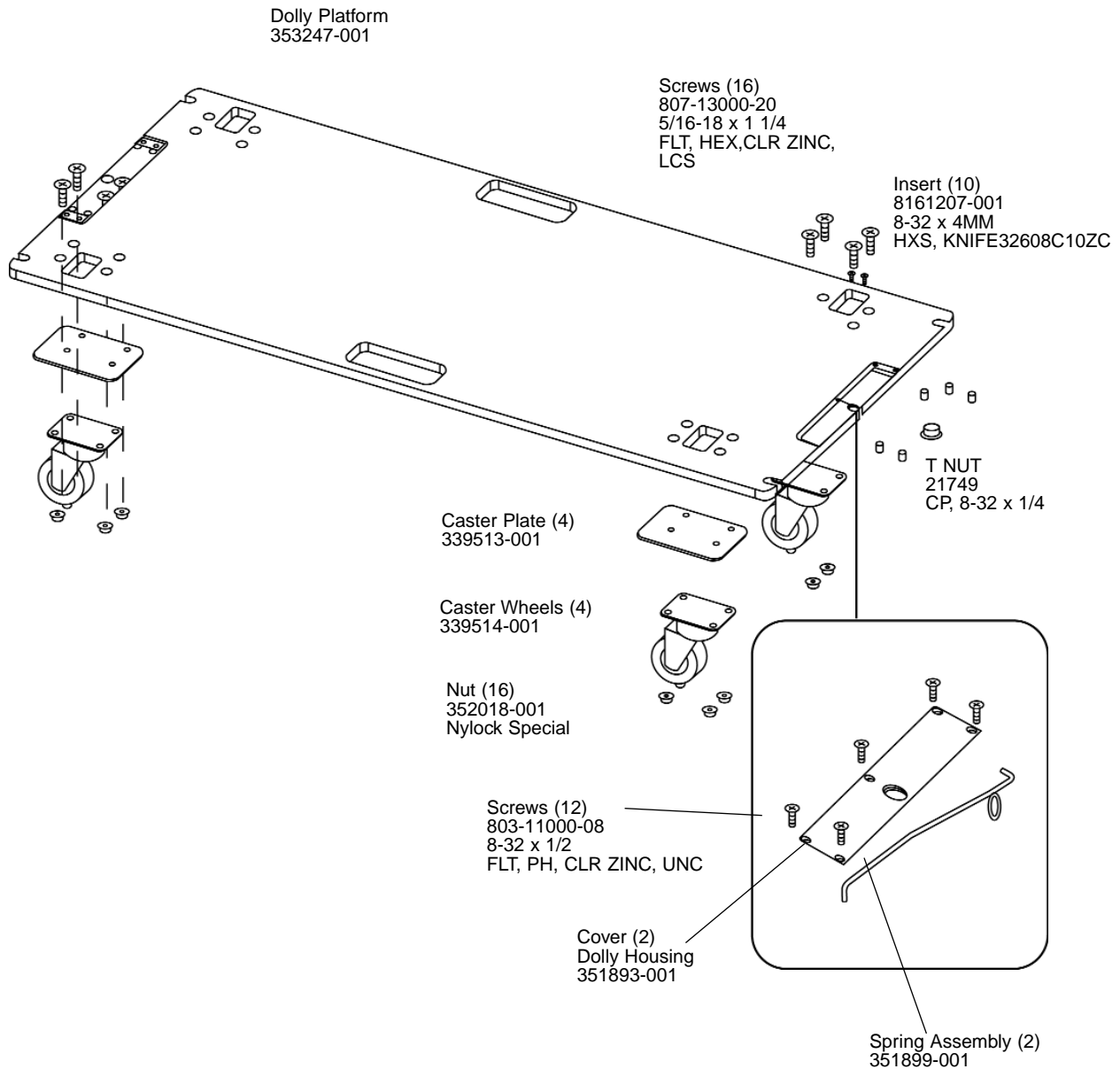

JBL VT4888-ACC

JBL VT4888-SF

ARRAY FRAME ASSEMBLY

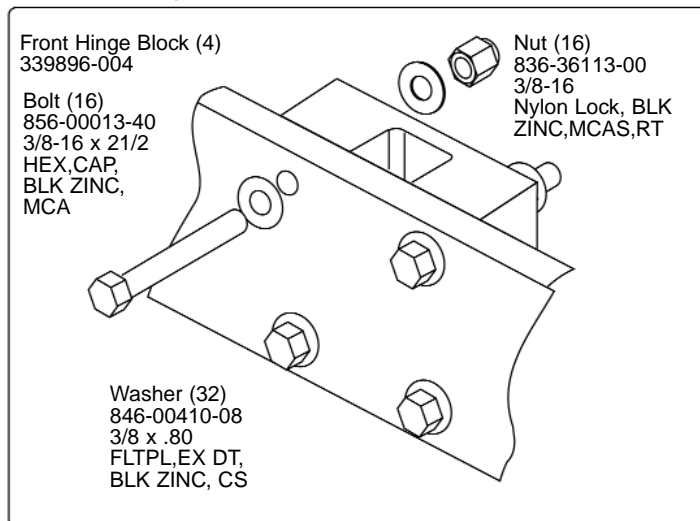
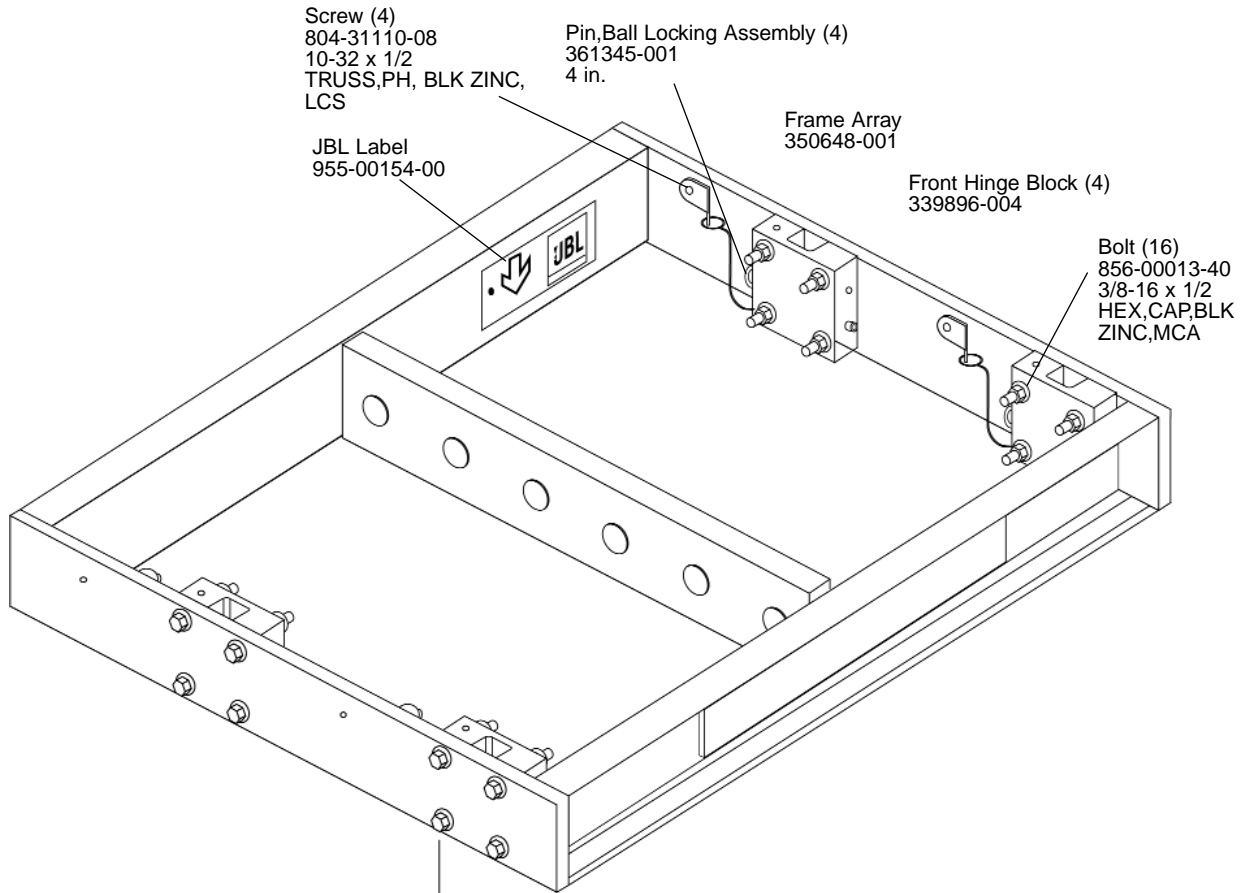

JBL VT4888-AF

ARRAY FRAME ASSEMBLY

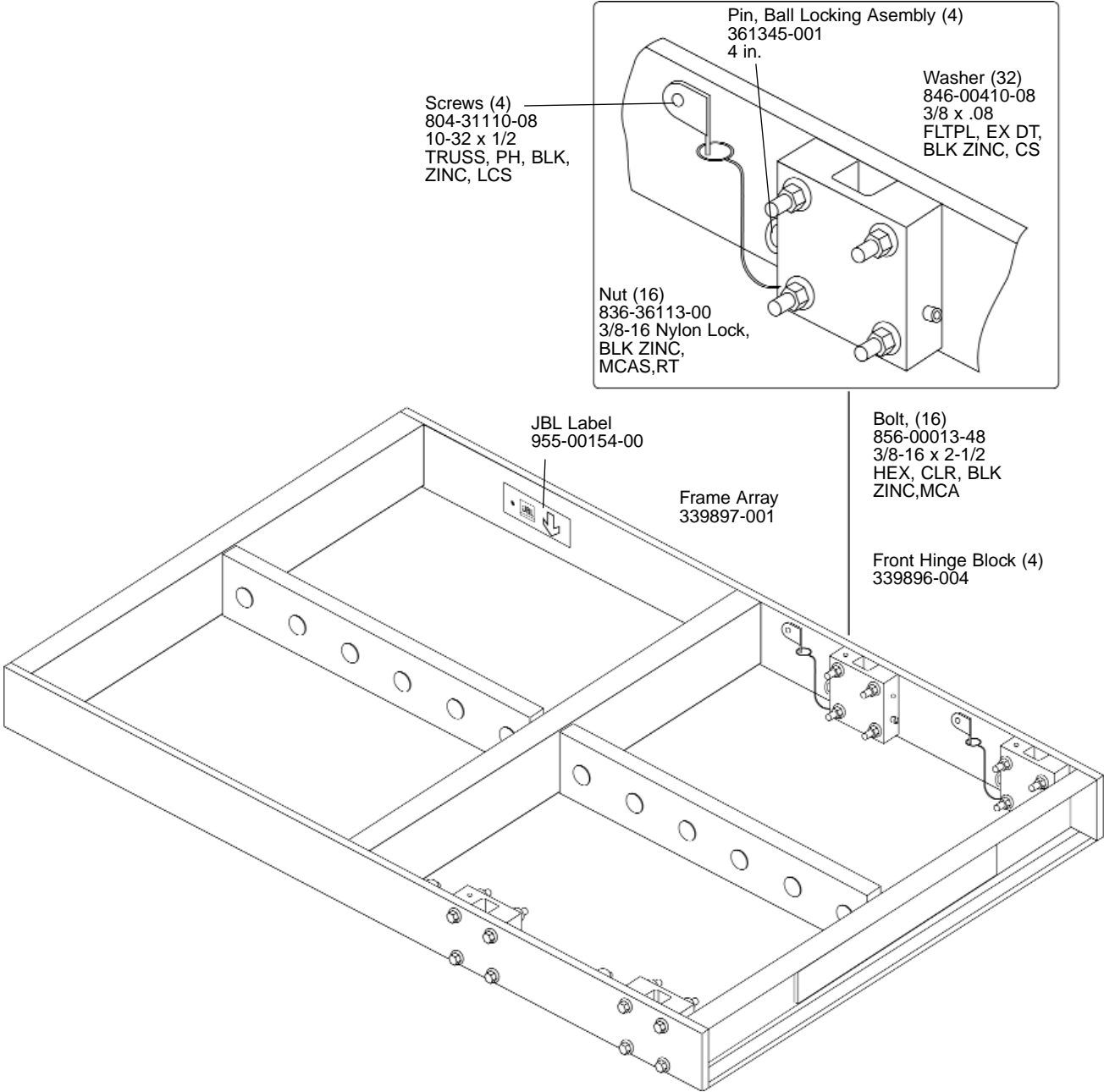

JBL VT4888-AF