

Technical Manual



JBL VT4881ADP-AN/CN/DA

SPECIFICATIONS

ACOUSTIC & ELECTRICAL SPECIFICATIONS:

- Nominal Impedance: 8 ohms
- Power Handling: 2000W Continuous/8000W Peak (AES/2 hrs)
- DP1 Internal Amplification Output: 1200W Continuous/4800W Peak (100 hrs)
- DP1 Output Topology: 3600W Peak, 1800 W Continuous
- DP1 Output Topology: 1-Channel Class-I
- Frequency Response: 34 Hz - 125 Hz (-3 dB)
- Frequency Range: 25 Hz - 160 Hz (-10 dB)
- Max Peak Output: 131 dB SPL, 1m
- Signal Processing: dbx type IV Conversion System, Precision bandpass filters, limiting, pre-equalization filters and automatic self-test functions.
- AC Power Operating Range: Auto Select 90-132VAC/216-264VAC, 50/60Hz
- AC Line Voltage: 50/60n Hz, Auto-Detect, 100V/220V,
- AC Input Connector: Neutrik PowerCon
- AC Power Loop-thru: Neutrik PowerCon
- AC Current Requirement: 5A per system at 120A, 3.2A per system at 240V

SYSTEM COMPONENTS:

- Cabinet: Enclosure Assembly C4881
- Grille: 354690-001
- Low Frequency: 2269G, 457 mm (18in) dia, 100mm (4 in) Dual Coil, Differential Drive[®] Direct Cooled^(TM)
- DC Resistance: 2.7 ohms

AURAL SWEEP TEST SPECIFICATIONS:

- A. System Aural Sweep Test: 7.0mV Input, 20 Hz to 400 Hz
- B. LF. Aural Sweep Test: 10.0V Input, 10 Hz to 300 Hz

PHYSICAL SPECIFICATIONS:

- Enclosure Dimensions: 787 mm x 569 mm x 800 mm (31 in. x 22.4 in. x 31.5 in.)
- Net Weight: 137 lbs. (62.2 kg)

WARRANTY INFORMATION:

- Refer to Warranty Statement packed with each product.

PACKAGE

- Warranty 59660
- Specification Sheet 362884-001
- Filler (2) 362308-001
- Microfoam (8) 49790P
- Carton 362307-002
- Protective Jackets (2) 360849-001
- JBL Drive Pack Operators Guide 362870-001
- Power Cord Assembly 355040-002 Edison / Shucko
- Back Filler (2) 363135-001
- Front Filler 363137-001
- CD, Network Drive Pack 361908-003
- JBL VT4881ADP-ACC Dolly Assembly 350434-003
- Carton 363005-001
- Filler, Bottom (2) 363006-001
- Filler, Top (2) 363007-001
- Exterior Cover 363019-001
- Filler, Pad (2) 363008-001

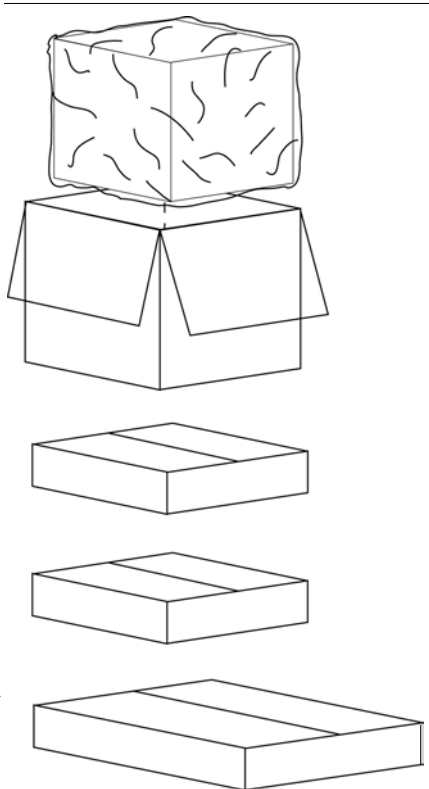

JBL VT4887-AF Carton 350712-001	JBL VT4887-SF Carton 350487-001
Filler (2) 350713-001	Filler (2) 350486-001
Owner's Manual 350485-001	Owner's Manual 350485-001

WIRING

Driver, Low Freq.
2269G
(354096-003X)
Cone Repl
C4R2269

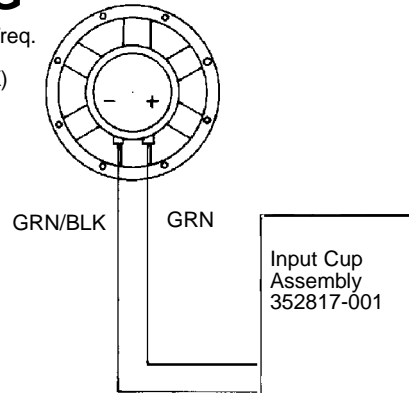

SCHEMATIC: 362309-001
Wiring Harness

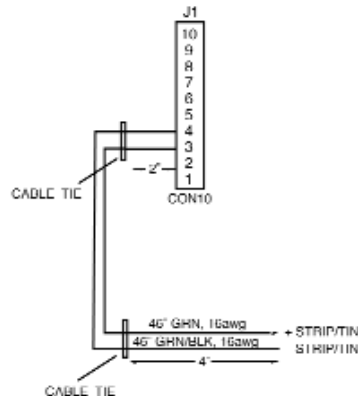

JBL VT4881ADP-AN/CN/DA REV M

JBL VT4881ADP-AN/CN/DA

SCHEMATIC DIAGRAMS

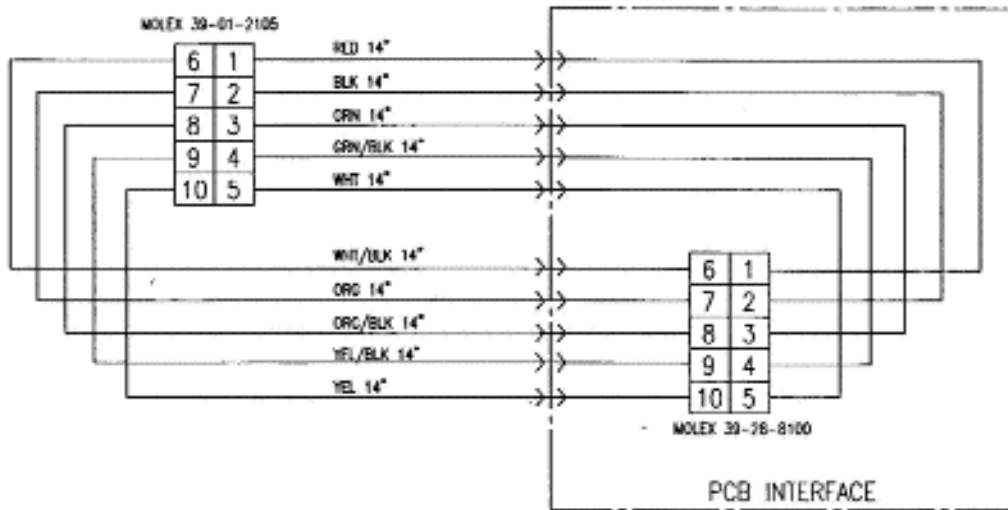

6	—————	SCREW MOUNT CABLE TIE*
5	-----	#6 X 3/8", TAP SCREW, PAN PH, BLK
4	352818-001	GASKET
3	352087-001	WIRE HARNESS (Ribbon Cable)
2	352270-001	PCB ASSY
1	352271-001	INPUT CUP

352270-001 Connector Assembly Diagram

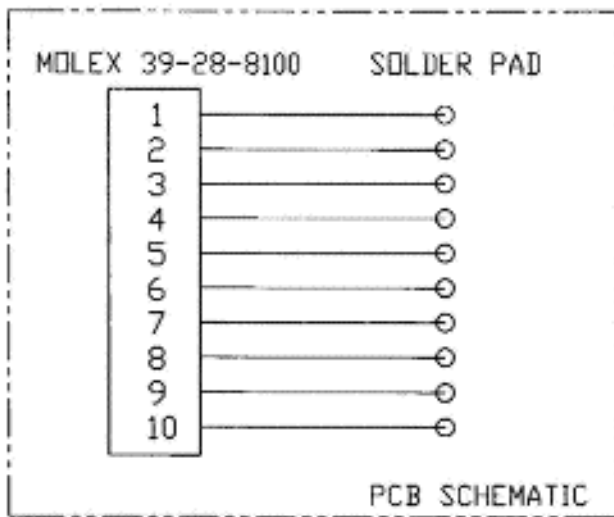

352087-001 Wire Harness Diagram

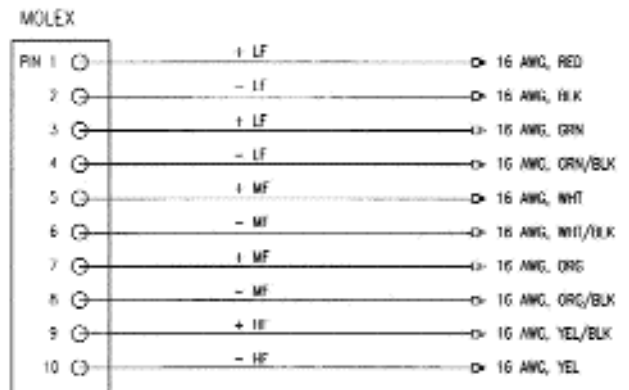

JBL VT4881ADP-AN/CN/DA

COMPONENT EXPLODED VIEW

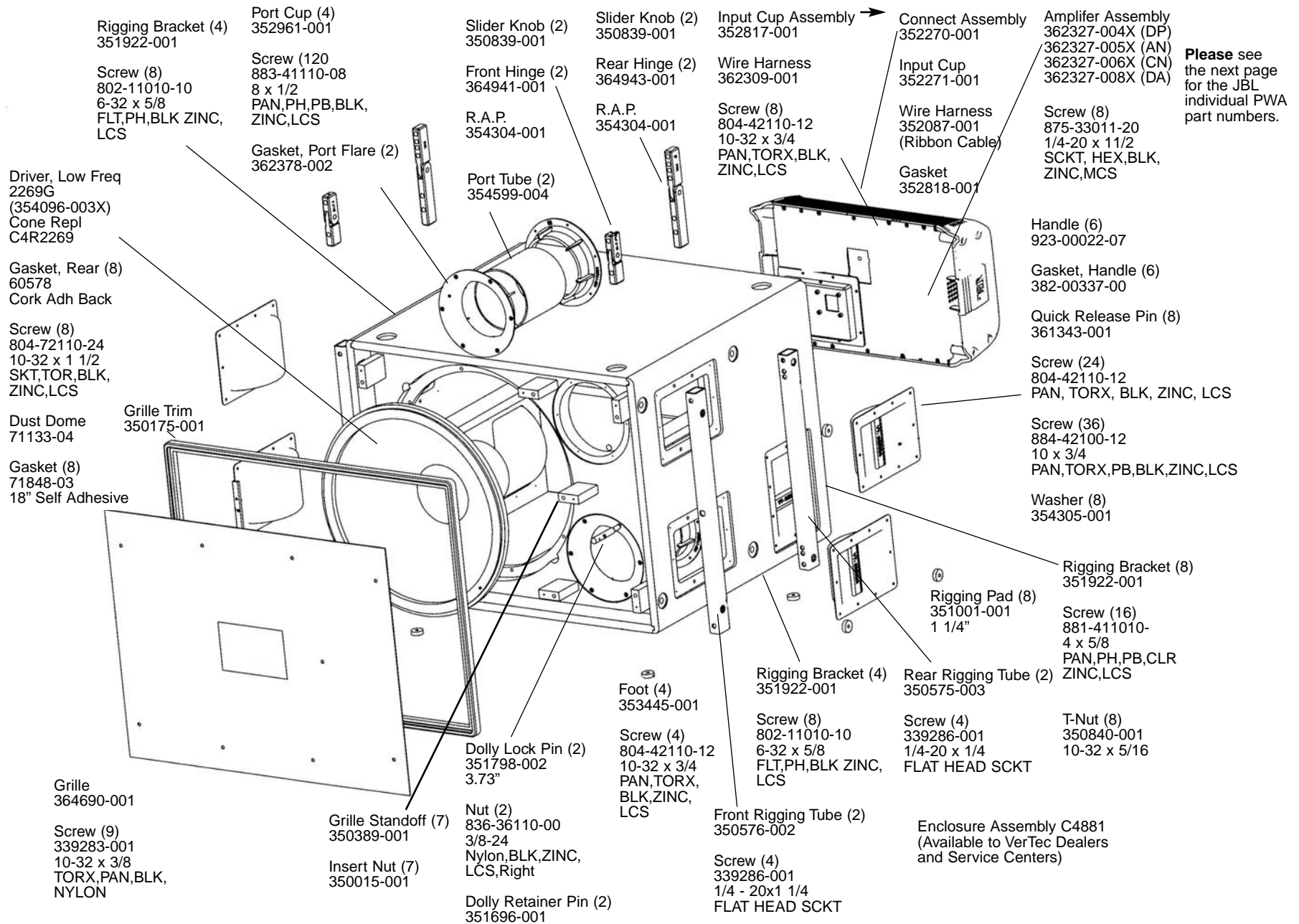

JBL VT4881ADP-AN/CN/DA

DP1 AMPLIFIER ASSEMBLY REFERENCE

AMPLIFIER ASSEMBLY 362327-001

Amplifier Assemblies

DP1

Note: Amplifier assembly includes the input module.

Part No.	Description
362327-001	Amplifier Assembly, Base Model, VP/VT Series
362327-002X	Amplifier Assembly, VPSB7118DPAN
362327-003X	Amplifier Assembly, VPSB7118DPCN
362327-004X	Amplifier Assembly, VT4881ADP
362327-005X	Amplifier Assembly, VT4881ADP-AN
362327-006X	Amplifier Assembly, VT4881ADP-CN
362327-007X	Amplifier Assembly, VPSB7118DP
362327-008X	Amplifier Assembly, VT4881DP-DA
362327-009X	Amplifier Assembly, VPSB7118DP-DA

Input Modules

Note: If ordering an input module you must order 1 of the tuning files below depending on the system model number.

	DP-dbx	DP-AN	DP-CN	DP-DA
	361541-001X	361092-001X	361093-001X	444668-001X
Model Numbers	Tuning File Part Numbers			
VT4881ADP	363146-001	363457-001	363458-001	445072-001
VPSB7118DP	364097-001	362351-001	362352-001	445119-001

NOTE: These (4) individual PWA's are out of the main panel:

PWA, DP1 PANEL
137084-6JBL

PWA, DP1 Main
137084-5AJBL

PWA, DP1 LF MOD
137084-5CJBL

PWA, DP1 LVPS
137084-5BJBL

PWA, DP1 SPKR INTERFACE
137084-5DJBL

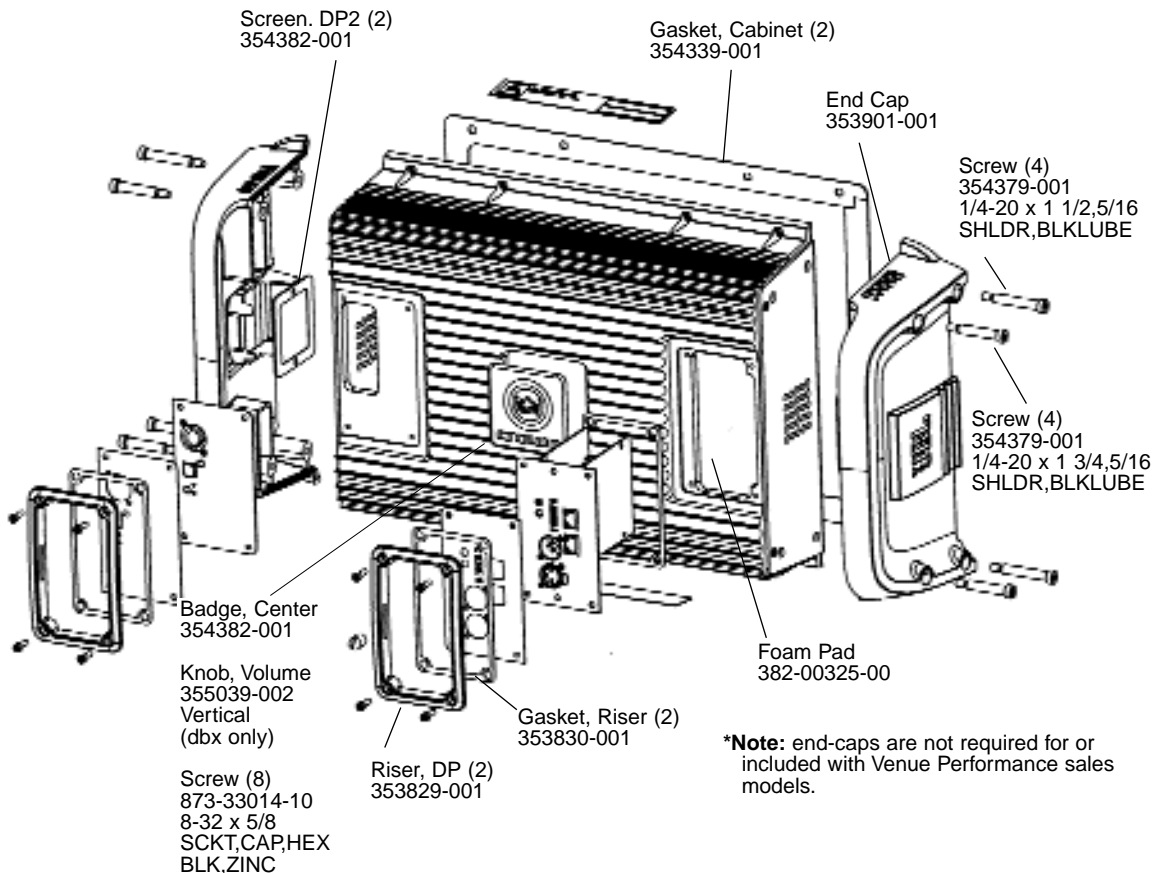

JBL VT4881ADP-ACC

DOLLY ASSEMBLY 350434-003

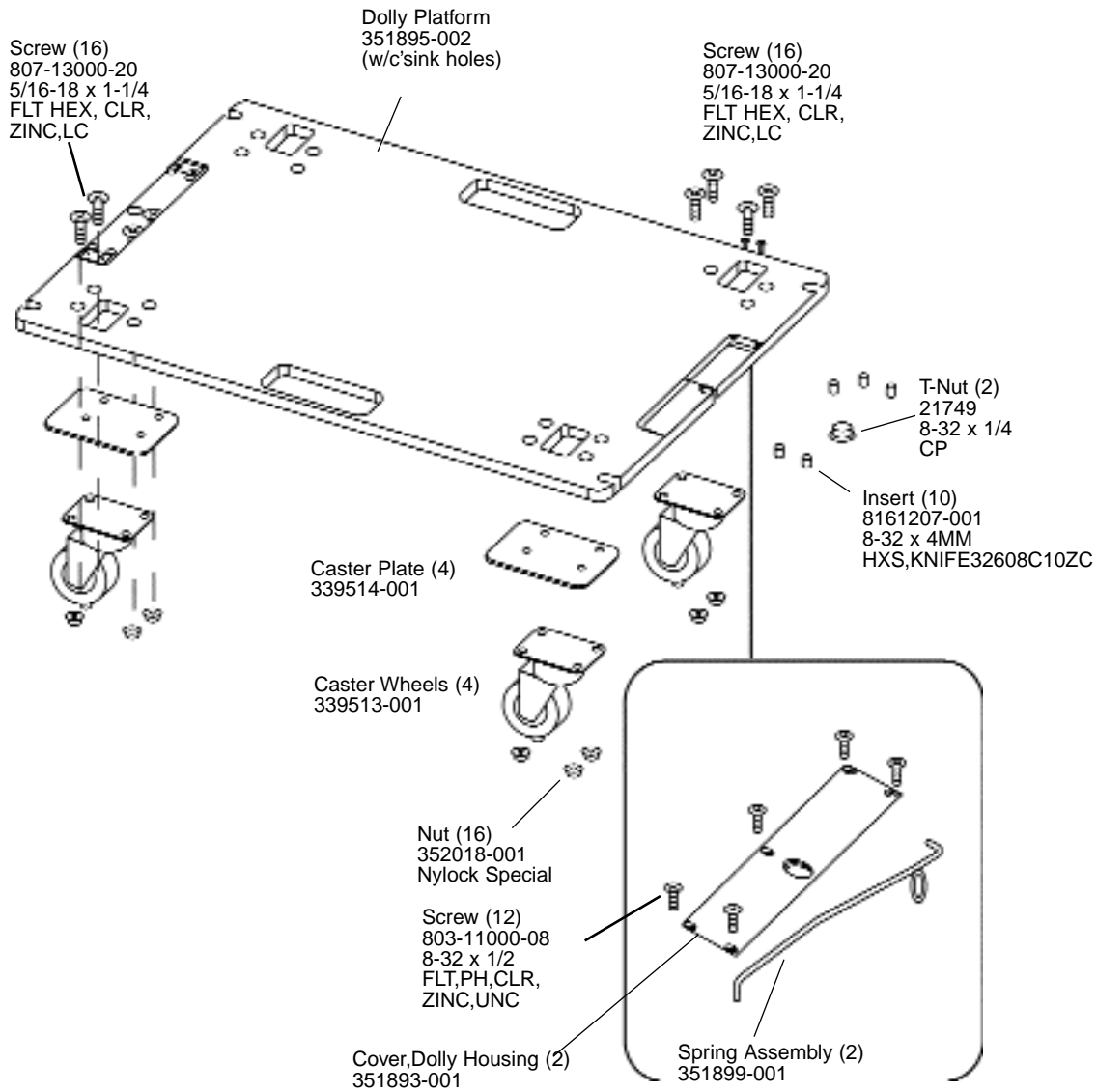

JBL VT4887-SF

ARRAY FRAME ASSEMBLY

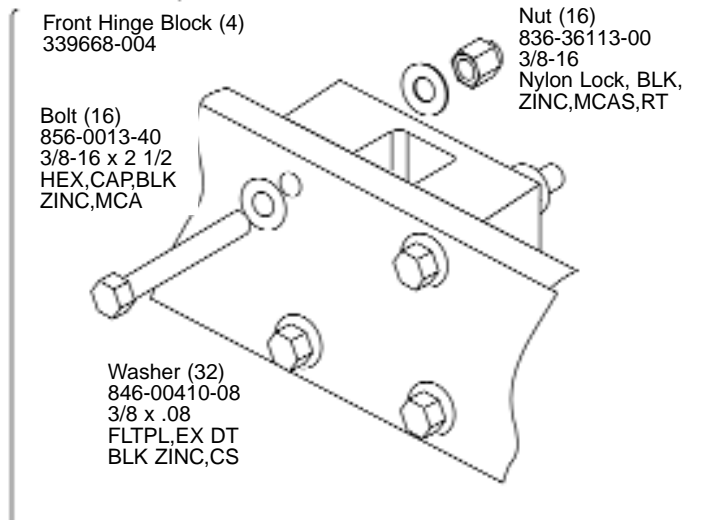
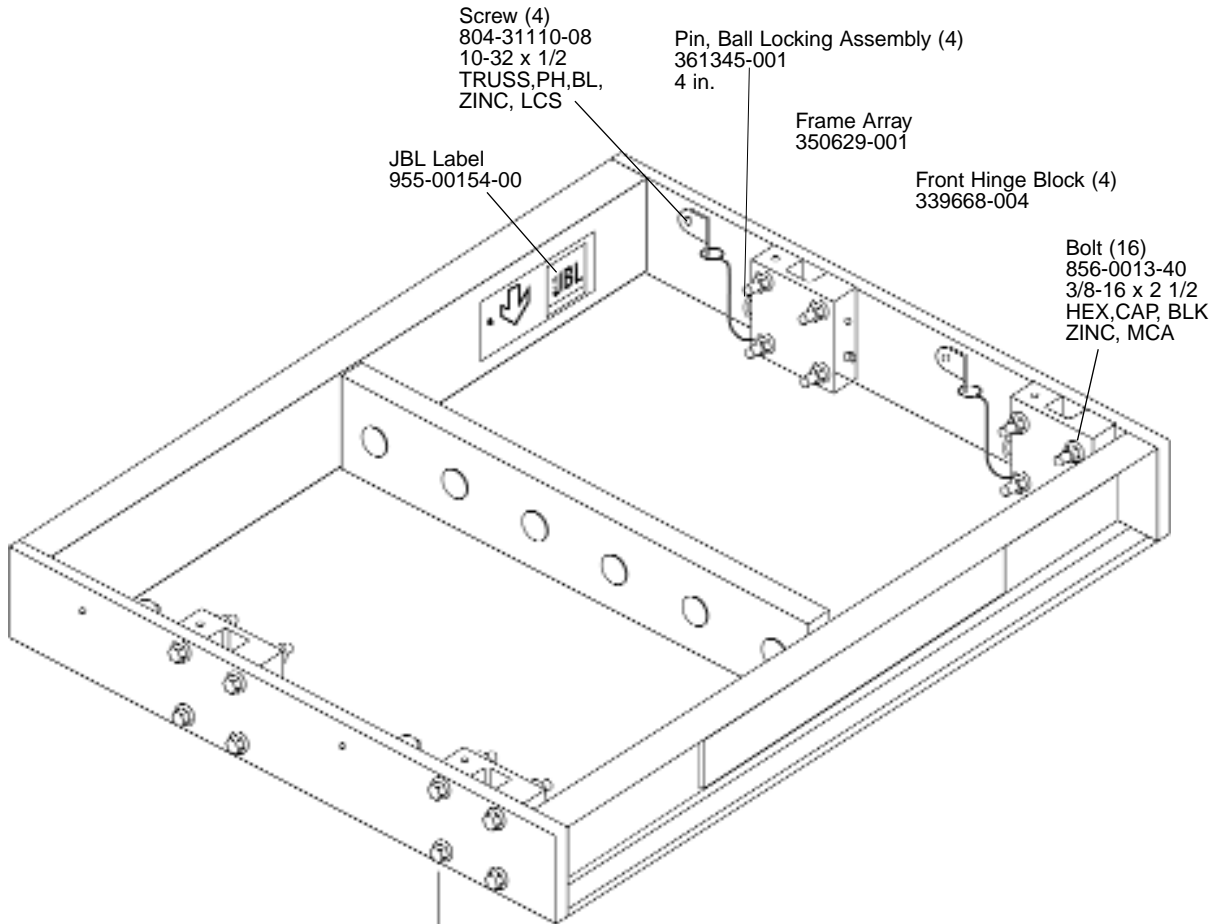

DP1 AMPLIFIER ASSEMBLY REFERENCE

JBL VT4887-AF

ARRAY FRAME ASSEMBLY

