

# Technical Manual

# JBL VS3218-9/WH



## SPECIFICATIONS

### ACOUSTIC & ELECTRICAL SPECIFICATIONS:

- Frequency Range: 33 Hz – 19 kHz (–10dB)
- Crossover Frequencies: 250 Hz – 1.3 kHz

### SYSTEM COMPONENTS:

- Cabinet: (Not For Sale)
- Grille: 128-00383-65, 128-00383-00 (Wh)
- Low Frequency Transducer: 460mm (18 in.) Cone Transducer (2242HPL)  
Nominal Impedance: 8 ohms  
Power Capacity: 800W AES: 3200W Peak  
Sensitivity: 99 dB SPL, 1 Watt @ 1 Meter  
DC Resistance: 4.7 ohm ± 10% Aluminum Wire
- Mid Frequency Transducer: 254mm (10 in.) Cone Transducer (2012HPL)  
Nominal Impedance: 8 ohms  
Power Capacity: 250W AES: 1000W Peak  
Sensitivity: 106 dB SPL, 1 Watt @ 1 Meter  
DC Resistance: 4.7 ohm ± 10% Aluminum Wire
- High Frequency Transducer: 100mm (4 in.) Pure Titanium Diaphragm (2447J)

### SYSTEM COMPONENTS: (cont'd)

- Nominal Impedance: 16 ohms
- Power Capacity: 75W AES: 300W Peak
- Sensitivity: 111 dB SPL, 1 Watt @ 1 Meter
- DC Resistance: 8.0 ohm ± 8% Aluminum Wire
- Crossover Network: 129-30008-00

### AURAL SWEEP TEST SPECIFICATIONS:

- A. L.F. Aural Sweep Test: 7.0V Input, 20 Hz to 1.2 kHz
- B. M.F. Aural Sweep Test: 7.0V Input, 250 Hz to 3 kHz
- C. H.F. Aural Sweep Test: 2.83V Input, 550 kHz to 20 kHz

### PHYSICAL SPECIFICATIONS:

- Enclosure Dimensions: 1213mm x 572mm x 572mm D (47.75 x 22.50 x 22.50 in. D)
- Net Weight: 165 lbs. (74.8 kg.)

### WARRANTY INFORMATION:

- Refer to Warranty Statement packed with each product.

## PACKAGE

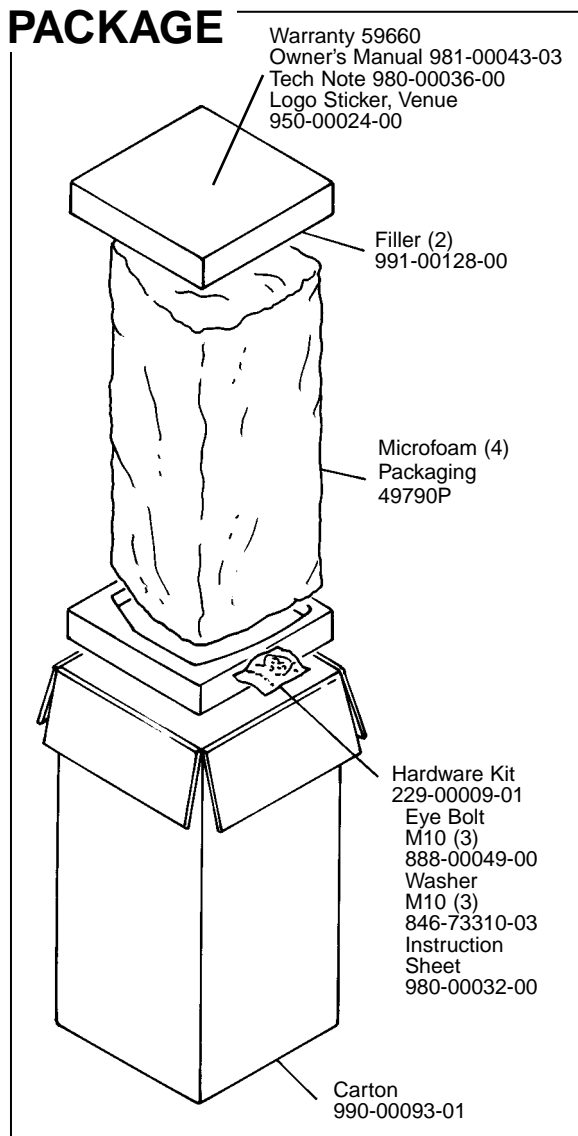

## WIRING DIAGRAM

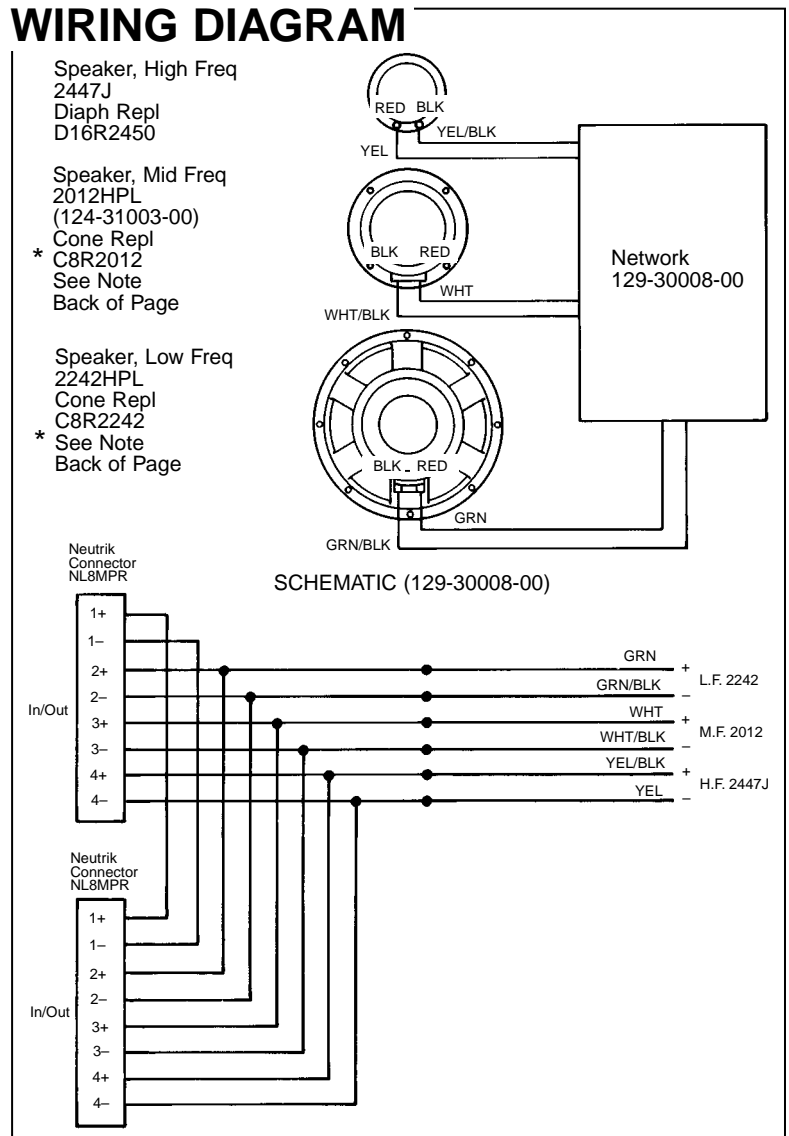

# JBL VS3218-9/WH

## COMPONENT EXPLODED VIEW

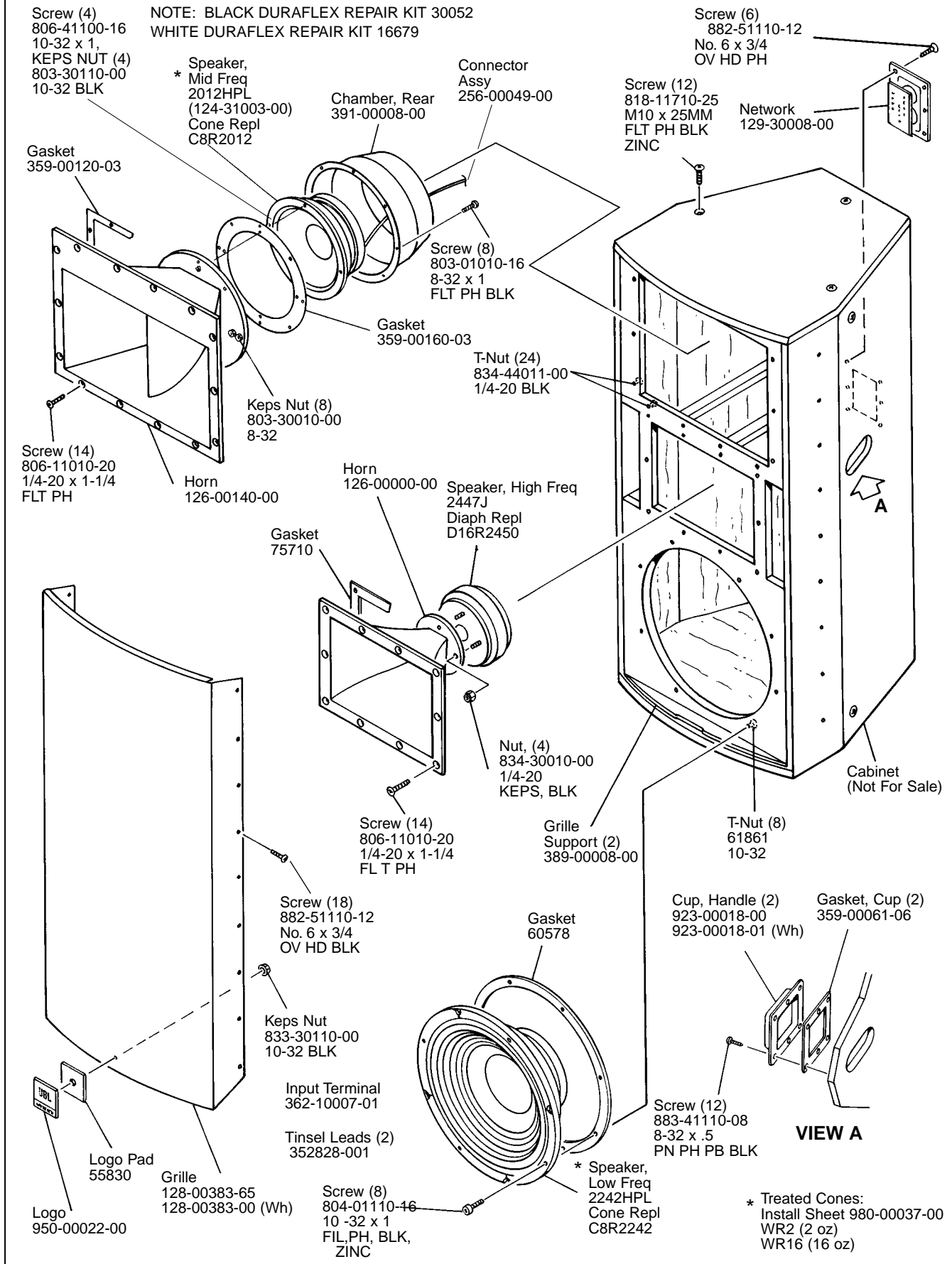

JBL VS3218-9/WH