

# Technical Manual

# JBL VS3115/WH



## SPECIFICATIONS

### ACOUSTIC & ELECTRICAL SPECIFICATIONS:

- Frequency Range: 32 Hz – 18 kHz (–10dB)
- Crossover Frequencies: 1.8 kHz – 340 Hz

### SYSTEM COMPONENTS:

- Cabinet: (Not For Sale)
- Grille: 128-00313-65, 128-00313-00 (Wh)
- Low Frequency Transducer: 380mm (15 in.) Cone Transducer (2226HPL)  
Nominal Impedance: 8 ohms  
Power Capacity: 600W AES: 2400W Peak  
Sensitivity: 97 dB SPL, 1 Watt @ 1 Meter  
DC Resistance: 5.0 ohm ± 10% Aluminum Wire
- Mid Frequency Transducer: 203mm (8 in.) Cone Transducer (M209-8A)  
Nominal Impedance: 8 ohms  
Power Capacity: 150W AES: 600W Peak  
Sensitivity: 105 dB SPL, 1 Watt @ 1 Meter  
DC Resistance: 5.3 ohm ± 10% Copper Wire

### SYSTEM COMPONENTS: (cont'd)

- High Frequency Transducer: 44mm (1.75 in.) Pure Titanium Diaphragm (2425HS)  
8 ohms  
Nominal Impedance: 8 ohms  
Power Capacity: 50W AES: 200W Peak  
Sensitivity: 111 dB SPL, 1 Watt @ 1 Meter  
DC Resistance: 3.2 ohm ± 8% Aluminum Wire
- Crossover Network: 129-30007-00

### AURAL SWEEP TEST SPECIFICATIONS:

- A. L.F. Aural Sweep Test: 7.0V Input, 20 Hz to 20 kHz
- B. M.F. Aural Sweep Test: 7.0V Input, 20 kHz to 20 kHz
- C. H.F. Aural Sweep Test: 2.0V Input, 550 kHz to 20 kHz

### PHYSICAL SPECIFICATIONS:

- Enclosure Dimensions: 924mm x 572mm x 572mm D (36.38 x 22.50 x 22.50 in. D)
- Net Weight: 105 lbs. (47.6 kg.)

### WARRANTY INFORMATION:

- Refer to Warranty Statement packed with each product.

## PACKAGE

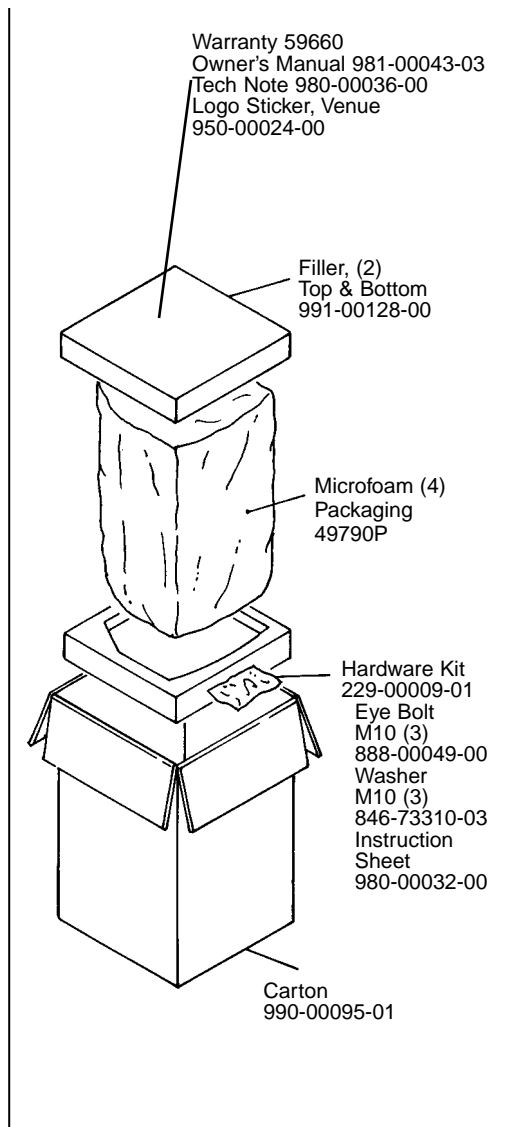

## WIRING DIAGRAM

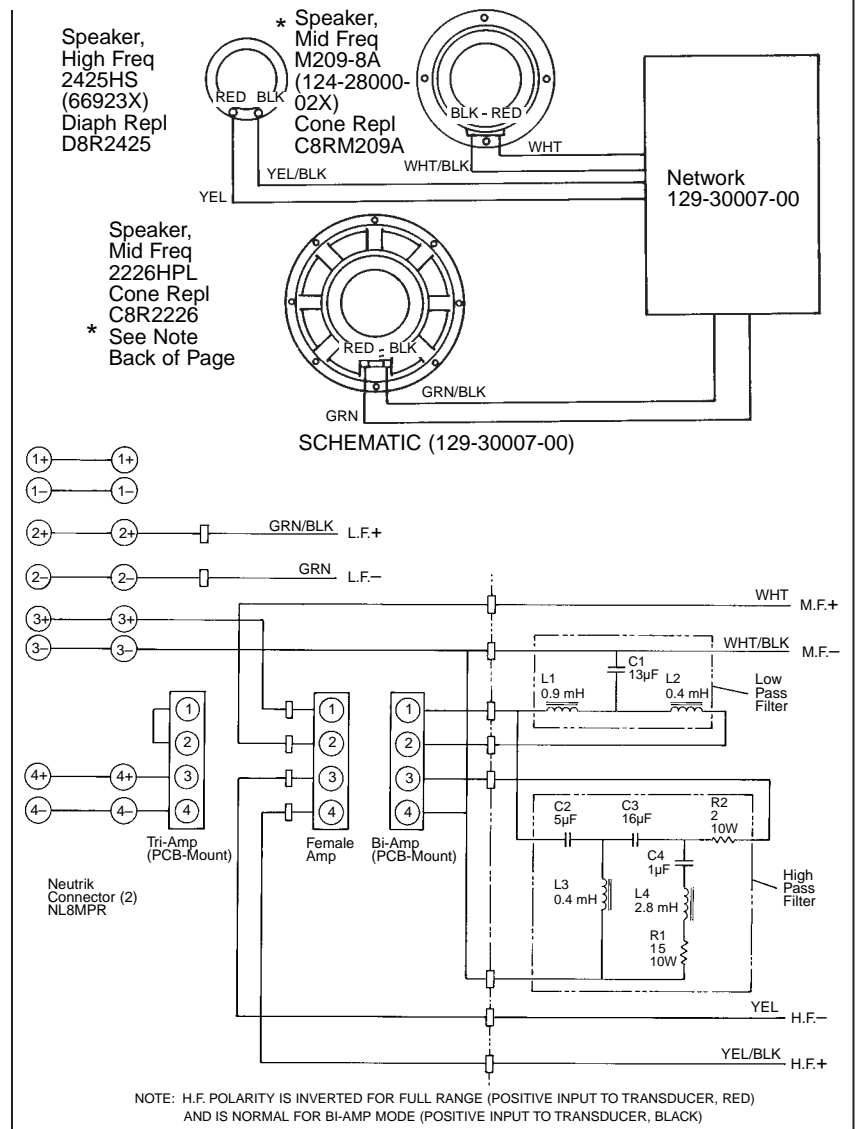

JBL VS3115/WH REV L

# JBL VS3115/WH

## COMPONENT EXPLODED VIEW

NOTE: BLACK DURAFLEX REPAIR KIT 16677

WHITE DURAFLEX REPAIR KIT 16679

\* Speaker, Mid Freq  
M209-8A  
(124-28000-02X)  
Cone Repl  
C8RM209A

Chamber  
391-00007-00

Connector Assy  
256-00049-00

Gasket  
359-00100-03

Screw (8)  
804-01110-16  
10-32 x 1  
FIL FLHD BLK

Speaker, High Freq  
2425HS  
(66923X)  
Diaph Repl  
D8R2425

Screw (4)  
804-01110-16  
10-32 x 1  
FIL PH BLK ZINC

Cabinet  
(Not For Sale)

Network  
129-30007-00

T-Nut (16)  
834-44011-00  
1/4-20 BLK

Gasket  
359-00130-03

Screw (16)  
806-31010-16  
1/4-20 x 1  
TRUSS PH BLK ZINC

Screw (6)  
882-51110-12  
6 x 3/4  
OV PH

Grille  
128-00313-65  
128-00313-00 (Wh)

Network  
129-30007-00

T-Nut (8)  
61861  
10-32

Screw (12)  
818-11710-25  
M10 x 25MM  
FLT PH BLK  
ZINC

Horn Assy  
126-00003-00

Grille  
Support (2)  
389-00008-00

Keps Nut (12)  
803-30110-00  
10-32

Gasket  
360-07000-03

Cup, Handle (2)  
923-00018-00  
923-00018-01(Wh)

Gasket, Cup (2)  
359-00061-06

Logo Pad  
55830

Screw (14)  
882-51110-12  
No. 6 x 3/4  
OV PH

Screw (12)  
883-41110-08  
10-32 X .5  
PN PH PB BLK

**VIEW A**

Logo  
950-00022-00

Screw (8)  
804-01110-16  
10-32 x 1  
FIL PH BLK

\* Speaker, Low Freq  
2226HPL  
Cone Repl  
C8R2226

\* Treated Cones:  
Install Sheet 980-00037-00  
WR-2 (2 oz)  
WR-16 (16 oz)

JBL VS3115/WH