

Technical Manual

JBL VS2210-6/WH



SPECIFICATIONS

ACOUSTIC & ELECTRICAL SPECIFICATIONS:

- Frequency Range: 215 Hz – 16 kHz (-10dB)
- Crossover Frequency: 1.3 kHz

SYSTEM COMPONENTS:

- Cabinet: (Not For Sale)
- Grille: 128-00303-65, 128-000303-00 (Wh)
- Mid Frequency Transducer: 254mm (10 in.) Cone Transducer (2012HPL)
- Nominal Impedance: 8 ohms
- Power Capacity: 250W AES: 1000W Peak
- Sensitivity: 108 dB SPL, 1 Watt @ 1 Meter
- DC Resistance: 4.7 ohm ± 10% Aluminum Wire
- High Frequency Transducer: 100mm (4 in.) Pure Titanium Diaphragm (2447J)
- Nominal Impedance: 16 ohms
- Power Capacity: 75W AES: 300W Peak

SYSTEM COMPONENTS: (cont'd)

- Sensitivity: 114 dB SPL, 1 Watt @ 1 Meter
- DC Resistance: 8.0 ohm ± 8% Aluminum Wire
- Crossover Network: 129-20033-00

AURAL SWEEP TEST SPECIFICATIONS:

- A. M.F. Aural Sweep Test: 7.0V Input, 250 Hz to 3 kHz
- B. H.F. Aural Sweep Test: 2.83V Input, 550 kHz to 20 kHz

PHYSICAL SPECIFICATIONS:

- Enclosure Dimensions: 728mm x 572mm x 572mm D (28.6 x 22.5 x 22.5 in. D)
- Net Weight: 91 lbs. (41.3 kg.)

WARRANTY INFORMATION:

- Refer to Warranty Statement packed with each product.

PACKAGE

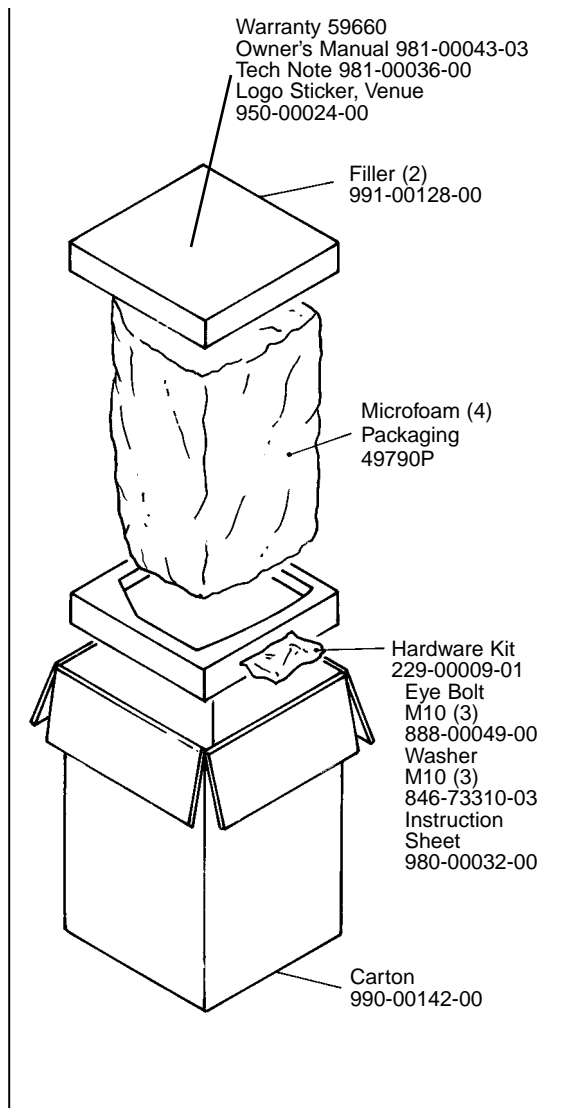

WIRING DIAGRAM

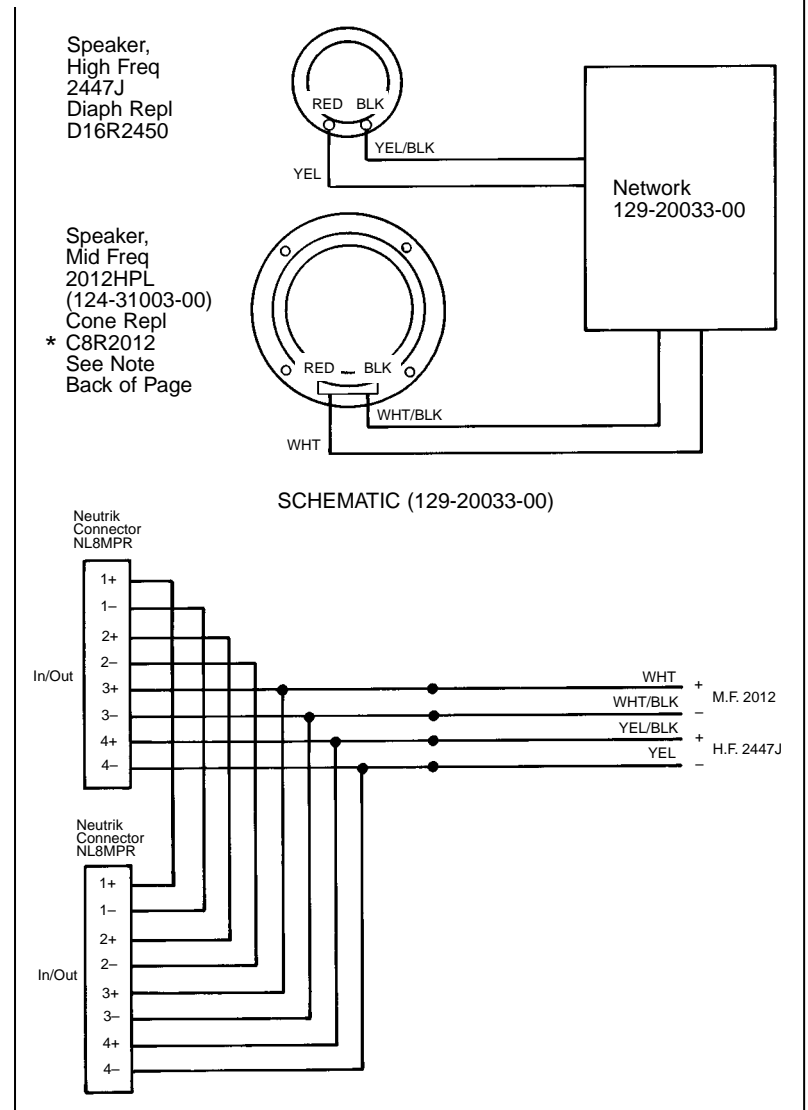

JBL VS2210-6/WH

COMPONENT EXPLODED VIEW

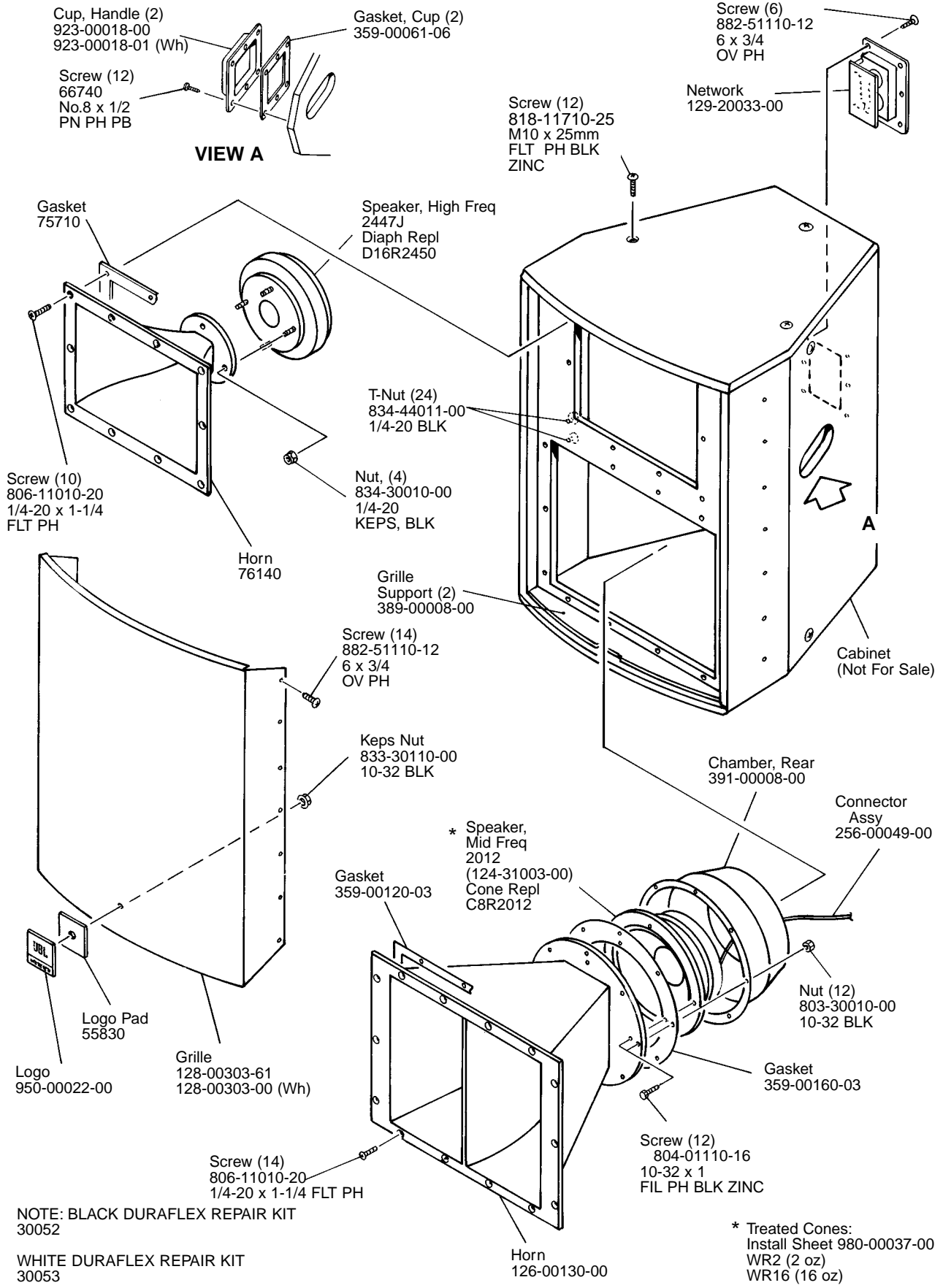

JBL VS2210-6/WH