

Technical Manual

JBL4670D-HF

SPECIFICATIONS



ACOUSTIC & ELECTRICAL SPECIFICATIONS:

- Nominal Impedance: 8 ohm
- Power Capacity: 100W Continuous Program above 500Hz
150W Continuous Program above 1 kHz
- Frequency Range: 500 Hz to 20 kHz
- Sensitivity: 111 dB SPL*
- Crossover Frequencies: N/A

SYSTEM COMPONENTS:

- Cabinet: N/A
- Grille: N/A
- Mounting Bracket: JBL 2509

*1 Watt (2.83 V RMS) @ 1 Meter

SYSTEM COMPONENTS: (cont'd)

- High Frequency Transducer: 100mm (4 in.) Pure Titanium Diaphragm (2446H)
- DC Resistance: 4.0 ohm \pm 8% Aluminum Wire
- Crossover Network: N/A

AURAL SWEEP TEST SPECIFICATIONS:

- A. H.F. Aural Sweep Test: 3.5V Input, 550 Hz to 20 kHz

PHYSICAL SPECIFICATIONS:

- Enclosure Dimensions: 492mm x 492mm x 519mm D (19.38 x 19.38 x 20.43in. D)
- Shipping Weight: 60 lbs. (27 kg)

WARRANTY INFORMATION:

- Refer to the Warranty Statement packed with each product.

PACKAGE

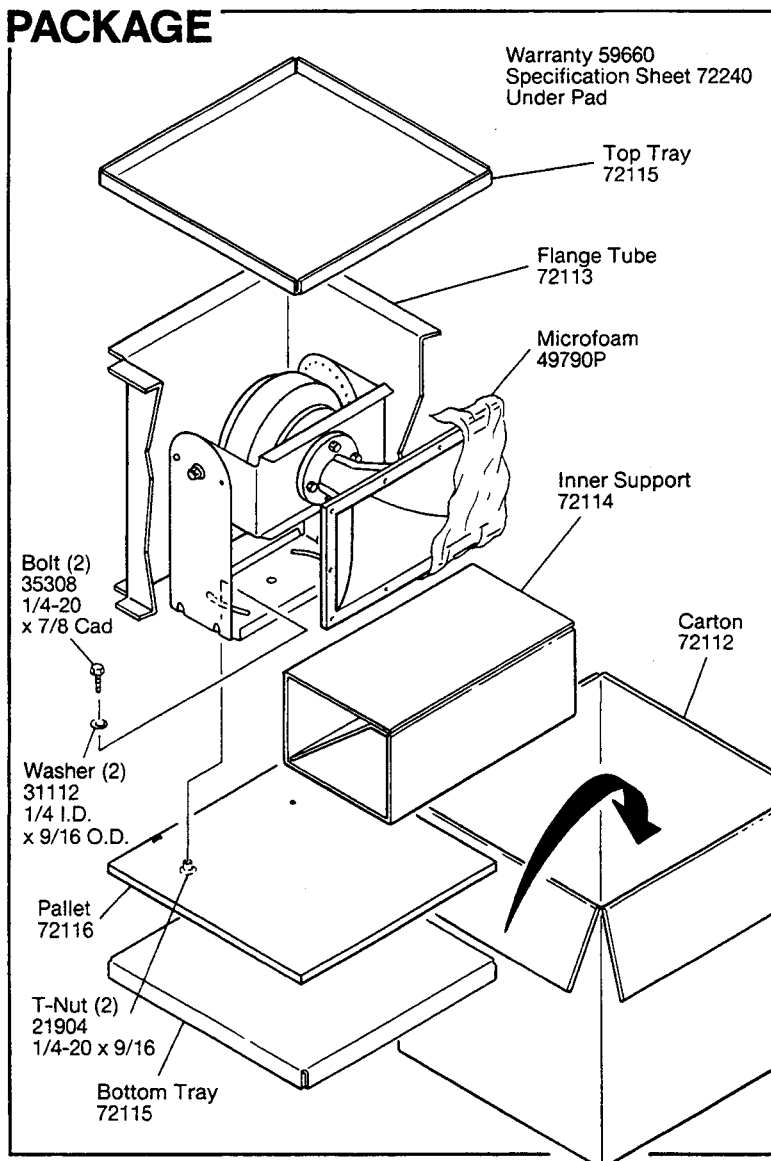

WIRING DIAGRAM

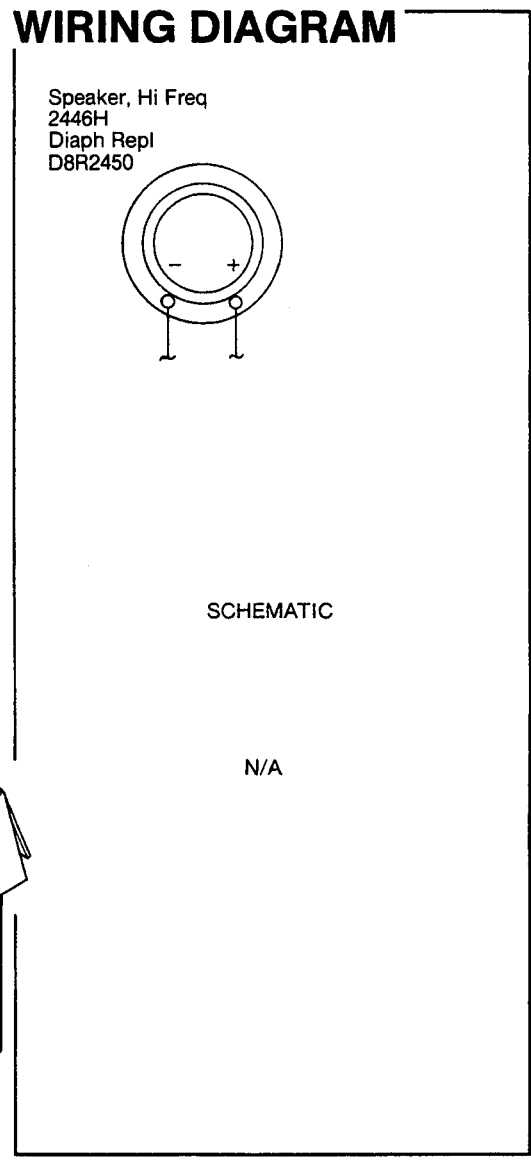

JBL4670D-HF REV C

JBL4670D-HF

COMPONENT EXPLODED VIEW

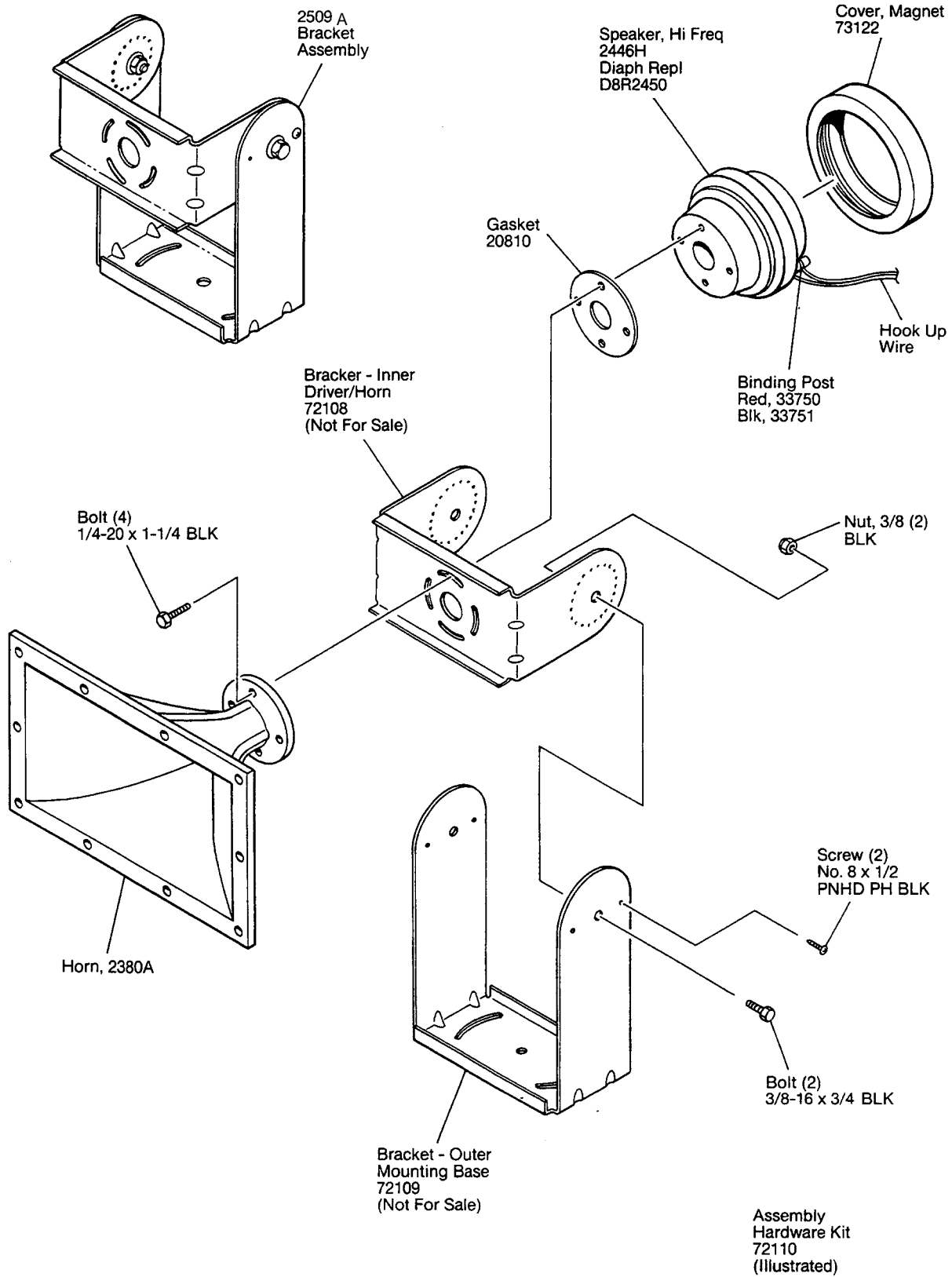

JBL4670D-HF