

Technical Manual

JBL3632-M/HF

SPECIFICATIONS



ACOUSTIC & ELECTRICAL SPECIFICATIONS:

- System: [3632-BI Specifications in Brackets]
- Frequency Range: 30Hz – 20kHz
- Frequency Response: 40Hz – 16kHz (± 3 dB)
- System Sensitivity: 103 dB, 2.83V @ 1m (3.3 ft)
- Rated Maximum SPL: 123 dB @ 1m (3.3 ft), 129 dB peak
- System Input Power Rating: 600 watts [LF: 500 watts, M/HF: 200 watts]
- Crossover Frequencies: 450 Hz, 2.0 kHz

SYSTEM COMPONENTS:

- Model 3632-M/HF
- Nominal Impedance: 4 ohms
- Input Power Rating: 200 watts AES; 300 watts Recommended Amplifier
- Sensitivity: 103 dB SPL, 2.83 V @ 1m (3.3 ft)
- Mid Frequency Transducer: 2 x 165H; 165mm (6.5 in) dia., 38mm (1.5 in) Voice Coil
- DC Resistance: 5.8 ohm $\pm 10\%$

SYSTEM COMPONENTS: (Cont'd)

- High Frequency Transducer: 2418H-1 44mm (1.75 in) Titanium Diaphragm and Voice Coil dia., 25mm (1 in) exit dia.
- DC Resistance: 3.2 ohm $\pm 8\%$ Aluminum Wire
- Crossover Network: 129-20066-01

AURAL SWEEP TEST SPECIFICATIONS:

- A. System Aural Sweep Test: 5.0V Input, 20 Hz to 20 kHz
- B. M.F. Aural Sweep Test: 5.0V Input, 100 Hz to 5 kHz
- C. H.F. Aural Sweep Test: 1.0V Input, 200 Hz to 1200 Hz

PHYSICAL SPECIFICATIONS:

- Enclosure Dimensions: 1054mm x 762mm x 450mm D (41.5 x 30.0 x 17.75 in. D)
- Shipping Weight: 100 lbs. (45.4 kg.)

WARRANTY INFORMATION:

- Refer to Warranty Statement packed with each product.

PACKAGE

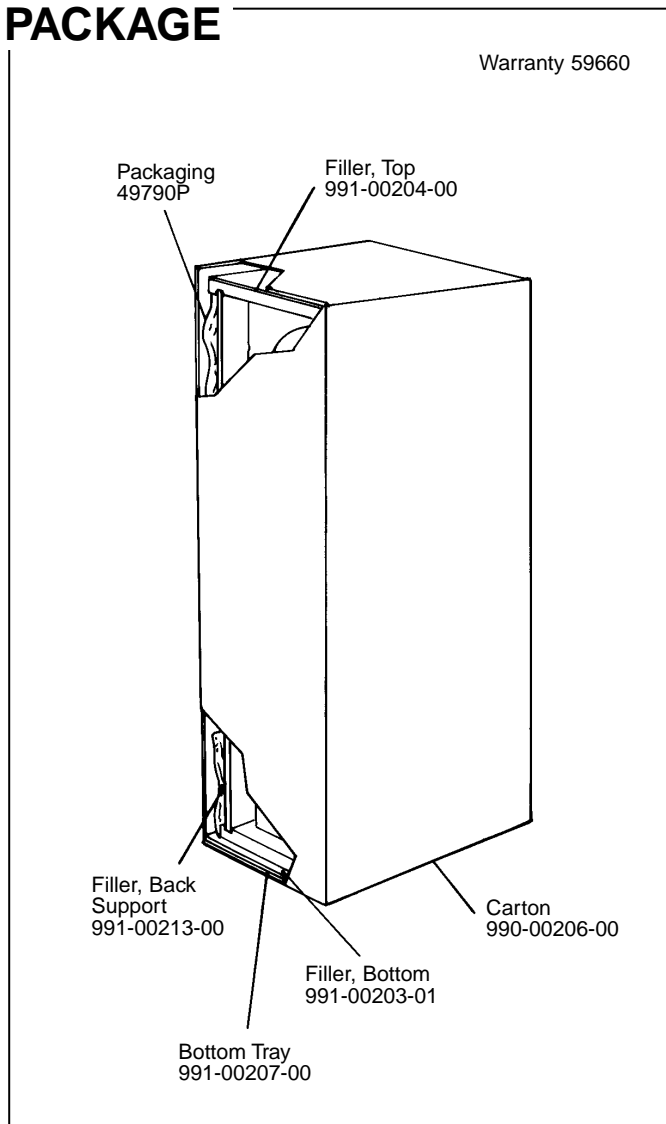

WIRING DIAGRAM

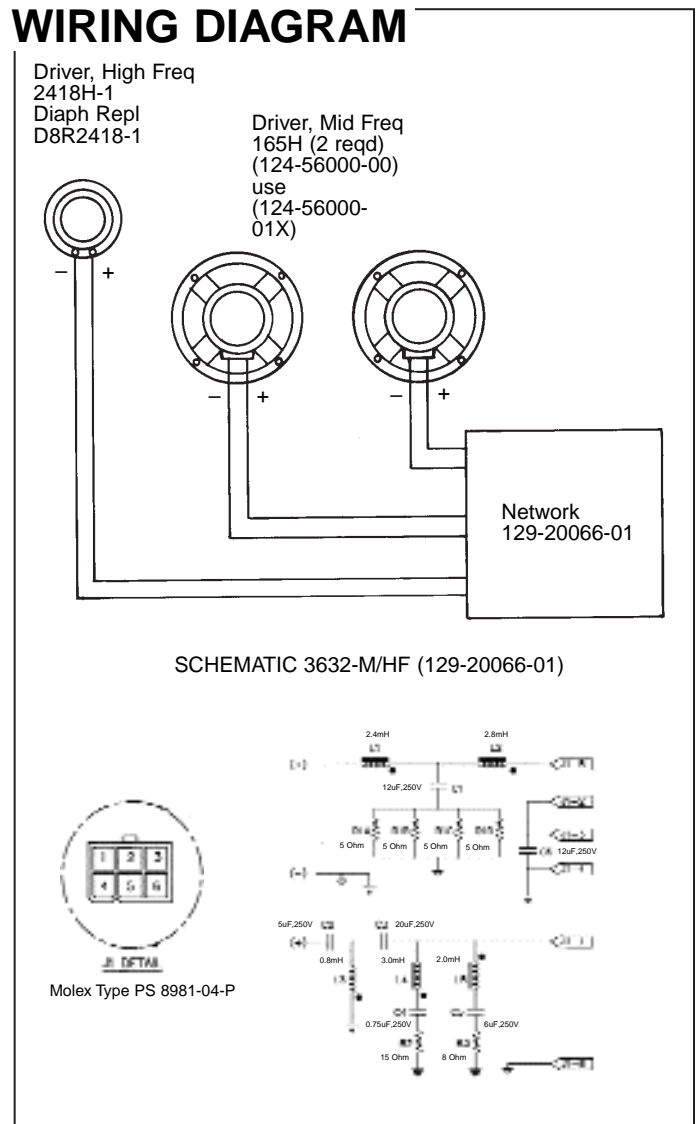

JBL3632-M/HF REV S

