

# Technical Manual

# JBL SP225-6/WH

## SPECIFICATIONS



### ACOUSTIC & ELECTRICAL SPECIFICATIONS:

- Nominal Impedance: 4 ohm
- Power Capacity: 1200W IEC: 4800W Peak
- Frequency Range: 33 Hz – 20 kHz (-10dB)
- Sensitivity: 100 dB SPL, 1 Watt @ 1 Meter
- Crossover Frequency: 1.2 kHz

### SYSTEM COMPONENTS:

- Cabinet: (Not For Sale)
- Grille: 128-00243-65, 128-00243-00 (Wh)
- Low Frequency Transducer: 380mm (15 in.) Cone Transducer (2226H) (2)
- DC Resistance: 5.0 ohm ± 10% Aluminum Wire
- High Frequency Transducer: 100mm (4 in.) Pure Titanium Diaphragm (2447J)
- DC Resistance: 8.0 ohm ± 8% Aluminum Wire

### SYSTEM COMPONENTS: (cont'd)

- Crossover Network: 129-20029-00

### AURAL SWEEP TEST SPECIFICATIONS:

- A. System Aural Sweep Test: 7.0V Input, 20 Hz to 20 kHz
- B. L.F. Aural Sweep Test: 7.0V Input, 20 Hz to 1.2 kHz
- C. H.F. Aural Sweep Test: 2.83V Input, 550 Hz to 20 kHz

### PHYSICAL SPECIFICATIONS:

- Enclosure Dimensions: 1151mm x 451mm x 451mm D (45.30 x 17.75 x 17.75 in. D)
- Shipping Weight: 138 lbs. (58 kg.)

### WARRANTY INFORMATION:

- Refer to Warranty Statement packed with each product.

## PACKAGE

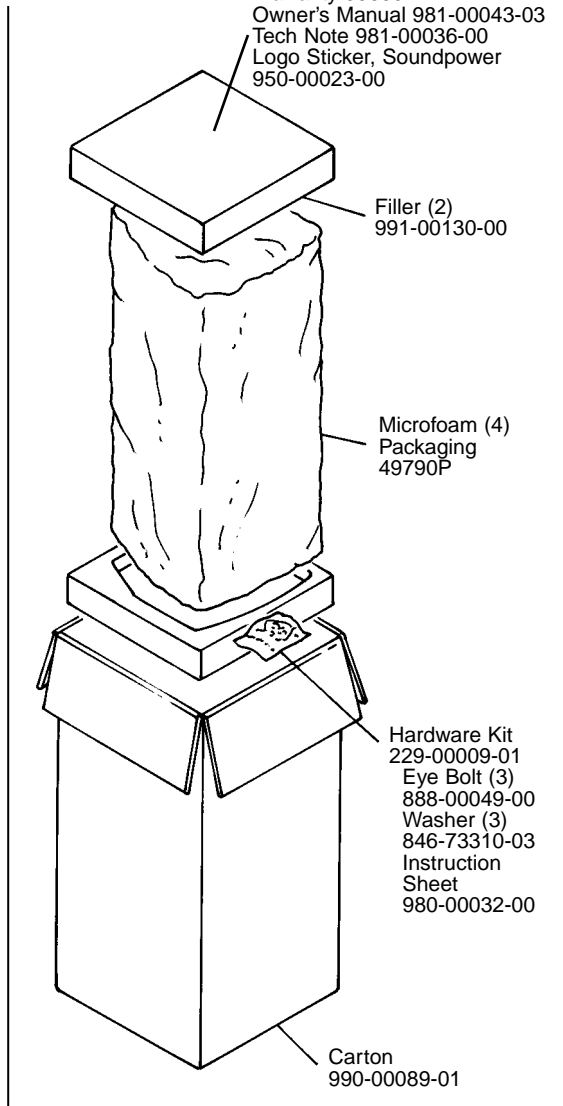

## WIRING DIAGRAM

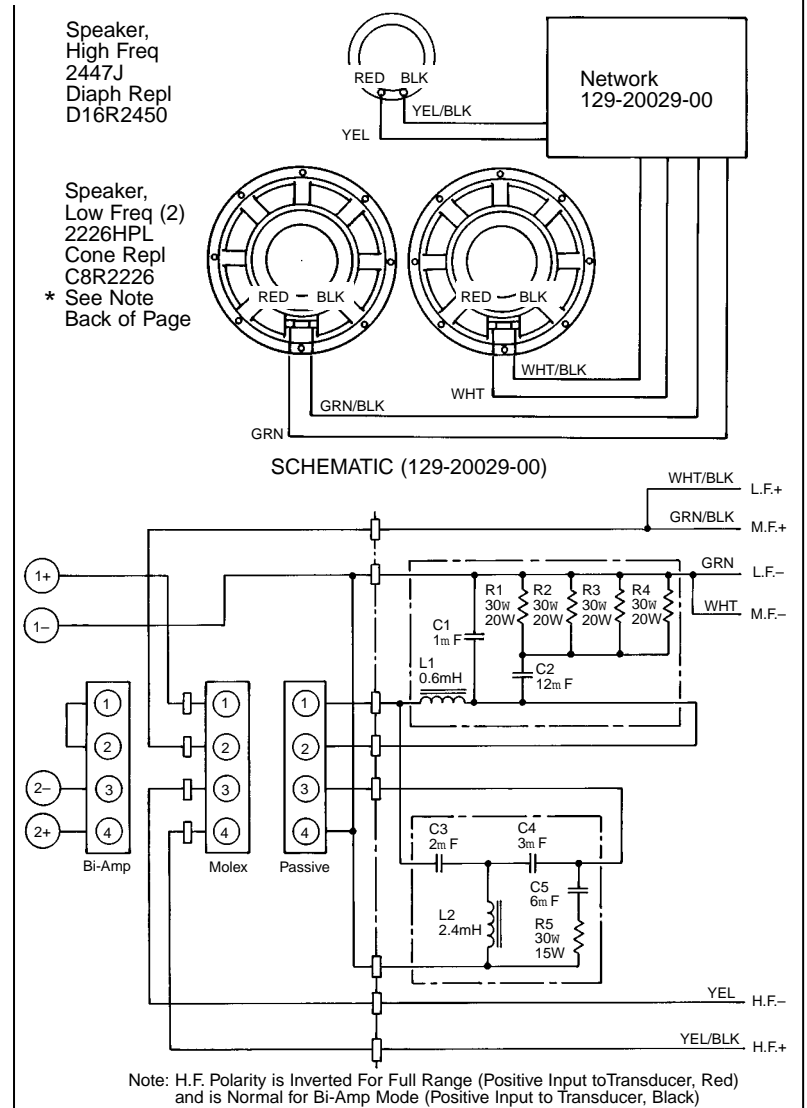

JBL SP225-6/WH REV N

# JBL SP225-6/WH

## COMPONENT EXPLODED VIEW

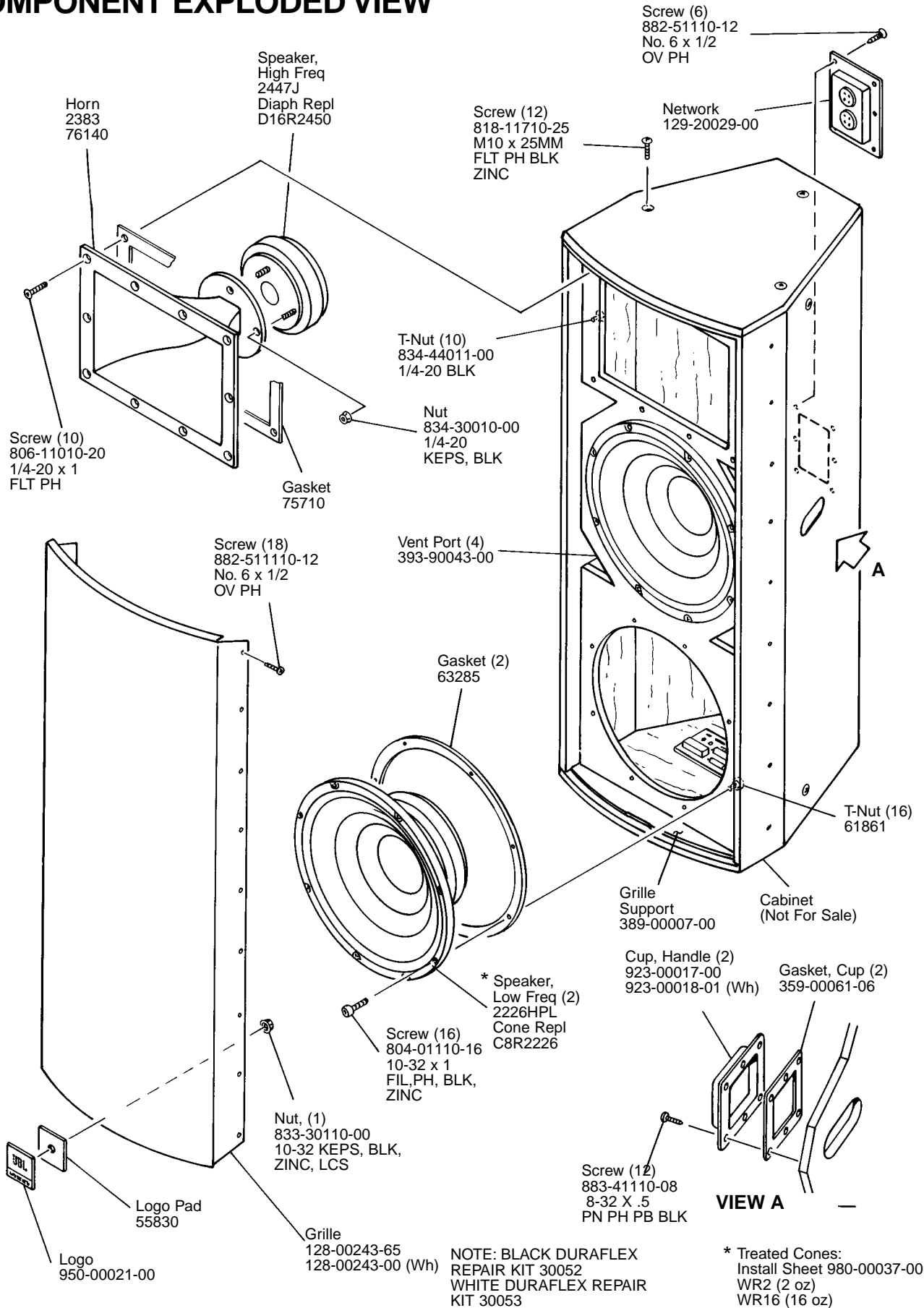

JBL SP225-6/WH