

Technical Manual

JBL SP215-6/WH



SPECIFICATIONS

ACOUSTIC & ELECTRICAL SPECIFICATIONS:

- Nominal Impedance: 8 ohm
- Power Capacity: 600W IEC: 2400W Peak
- Frequency Range: 33 Hz – 20 kHz (–10dB)
- Sensitivity: 97 dB SPL, 1 Watt @ 1 Meter
- Crossover Frequency: 1.2 kHz

SYSTEM COMPONENTS:

- Cabinet: (Not For Sale)
- Grille: 128-00253-65, 128-00253-00 (Wh)
- Low Frequency Transducer: 300mm (15 in.) Cone Transducer (2226HPL)
DC Resistance: 5.0 ohm ± 10% Aluminum Wire
- High Frequency Transducer: 100mm (4 in.) Pure Titanium Diaphragm (2447J)
DC Resistance: 8.0 ohm ± 8% Aluminum Wire

SYSTEM COMPONENTS: (cont'd)

- Crossover Network 129-20026-00

AURAL SWEEP TEST SPECIFICATIONS:

- A. System Aural Sweep Test: 7.0V Input, 20 Hz to 20 kHz
- B. L.F. Aural Sweep Test: 7.0V Input, 20 Hz to 1.2 kHz
- C. H.F. Aural Sweep Test: 2.0V Input, 550 Hz to 20 kHz

PHYSICAL SPECIFICATIONS:

- Enclosure Dimensions: 737mm x 448mm x 449mm D (29.0 x 17.64 x 17.68 in. D)
- Shipping Weight: 94 lbs. (42.6 kg.)

WARRANTY INFORMATION:

- Refer to Warranty Statement packed with each product.

PACKAGE

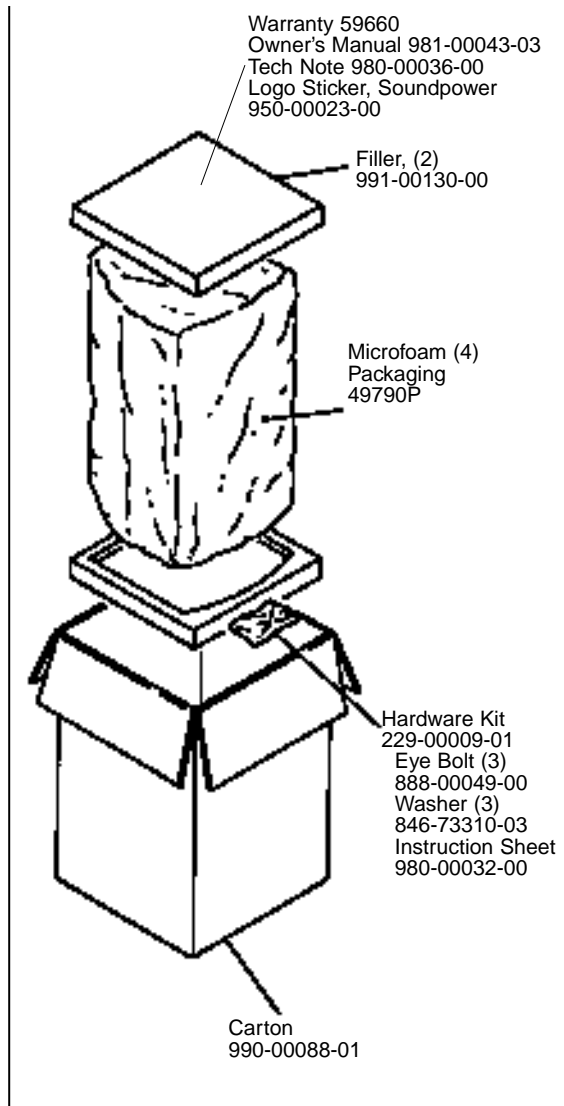

WIRING DIAGRAM

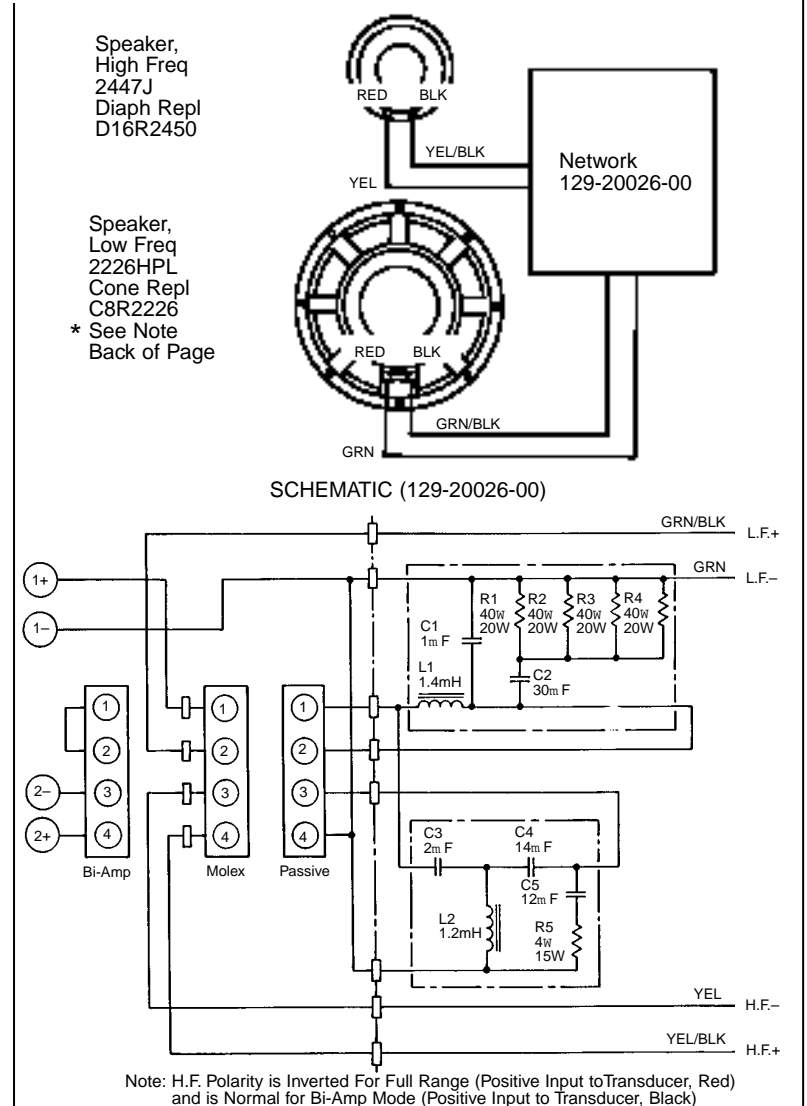

JBL SP215-6/WH REV M

JBL SP215-6/WH

COMPONENT EXPLODED VIEW

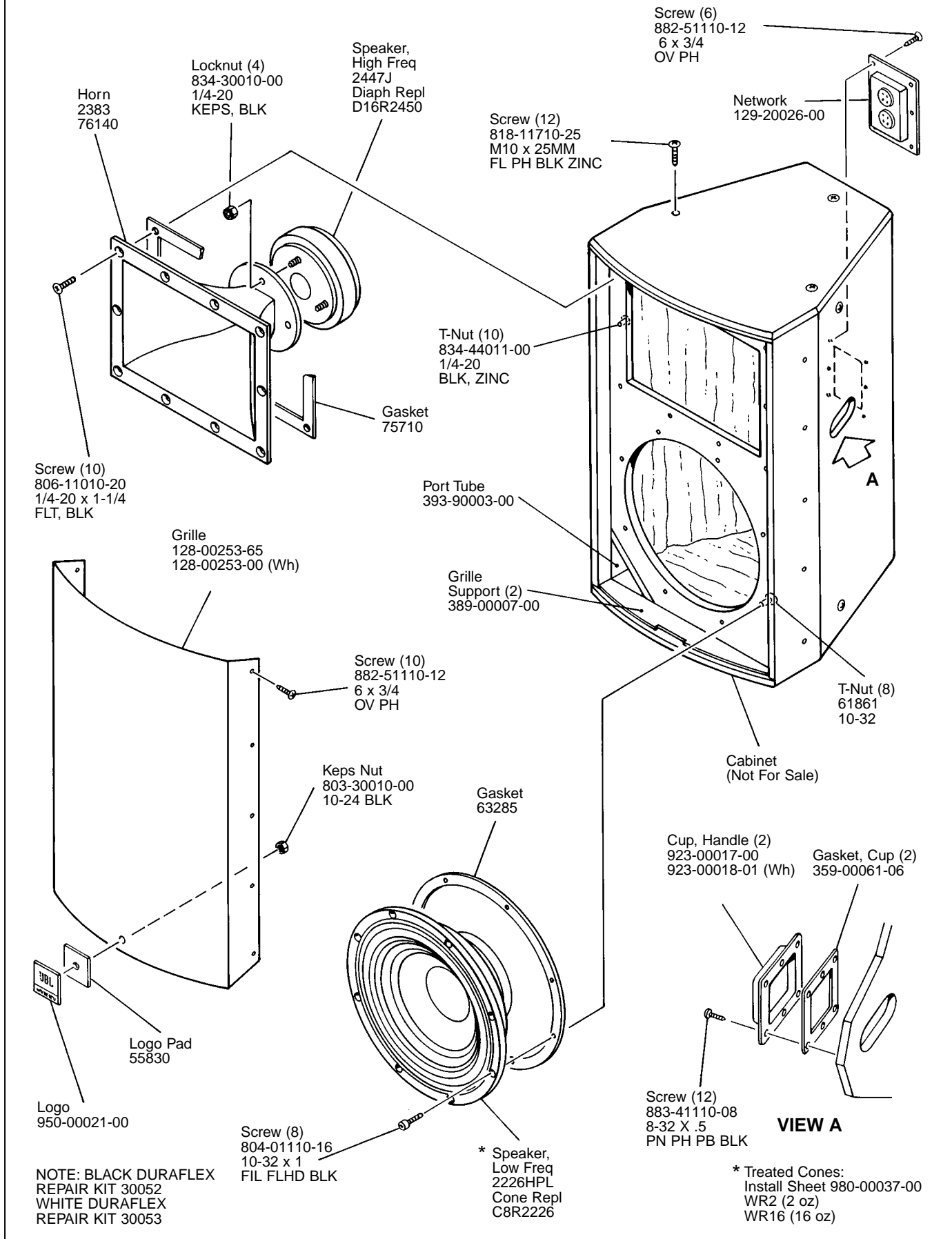

NOTE: BLACK DURAFLEX REPAIR KIT 30052
WHITE DURAFLEX REPAIR KIT 30053

JBL SP215-6/WH