

# Technical Manual

# JBL SP212-9/WH



## SPECIFICATIONS

### ACOUSTIC & ELECTRICAL SPECIFICATIONS:

- Nominal Impedance: 8 ohm
- Power Capacity: 600W IEC; 2400W Peak
- Frequency Range: 37 Hz – 20 kHz (–10dB)
- Sensitivity: 95 dB SPL, 1 Watt @ 1 Meter
- Crossover Frequency: 1.2 kHz

### SYSTEM COMPONENTS:

- Cabinet: (Not For Sale)
- Grille: 128-00273-65, 128-00273-00 (Wh)
- Low Frequency Transducer: 300mm (12 in.) Cone Transducer (2206HPL)  
DC Resistance: 5.3 ohm ± 10% Aluminum Wire
- High Frequency Transducer: 100mm (4 in.) Pure Titanium Diaphragm (2447J)  
DC Resistance: 8.0 ohm ± 8% Aluminum Wire

### SYSTEM COMPONENTS: (cont'd)

- Crossover Network 129-20032-00

### AURAL SWEEP TEST SPECIFICATIONS:

- A. System Aural Sweep Test: 7.0V Input, 20 Hz to 20 kHz
- B. L.F. Aural Sweep Test: 7.0V Input, 20 Hz to 1.2 kHz
- C. H.F. Aural Sweep Test: 2.83V Input, 550 Hz to 20 kHz

### PHYSICAL SPECIFICATIONS:

- Enclosure Dimensions: 585mm x 385mm x 402mm D (23.05 x 15.14 x 15.81 in. D)
- Shipping Weight: 80 lbs. (36.3 kg.)

### WARRANTY INFORMATION:

- Refer to Warranty Statement packed with each product.

## PACKAGE

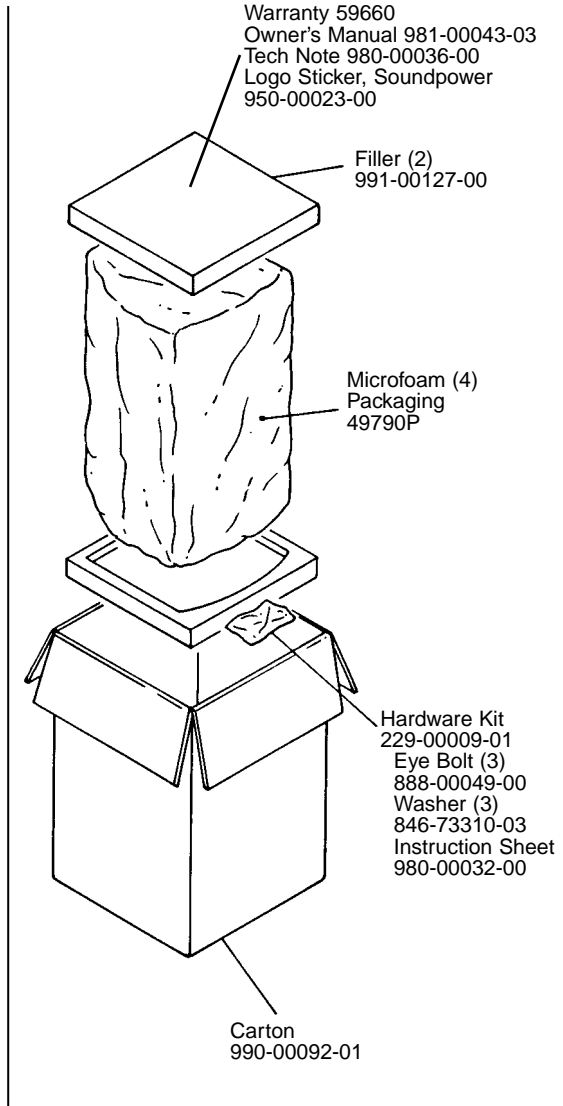

## WIRING DIAGRAM

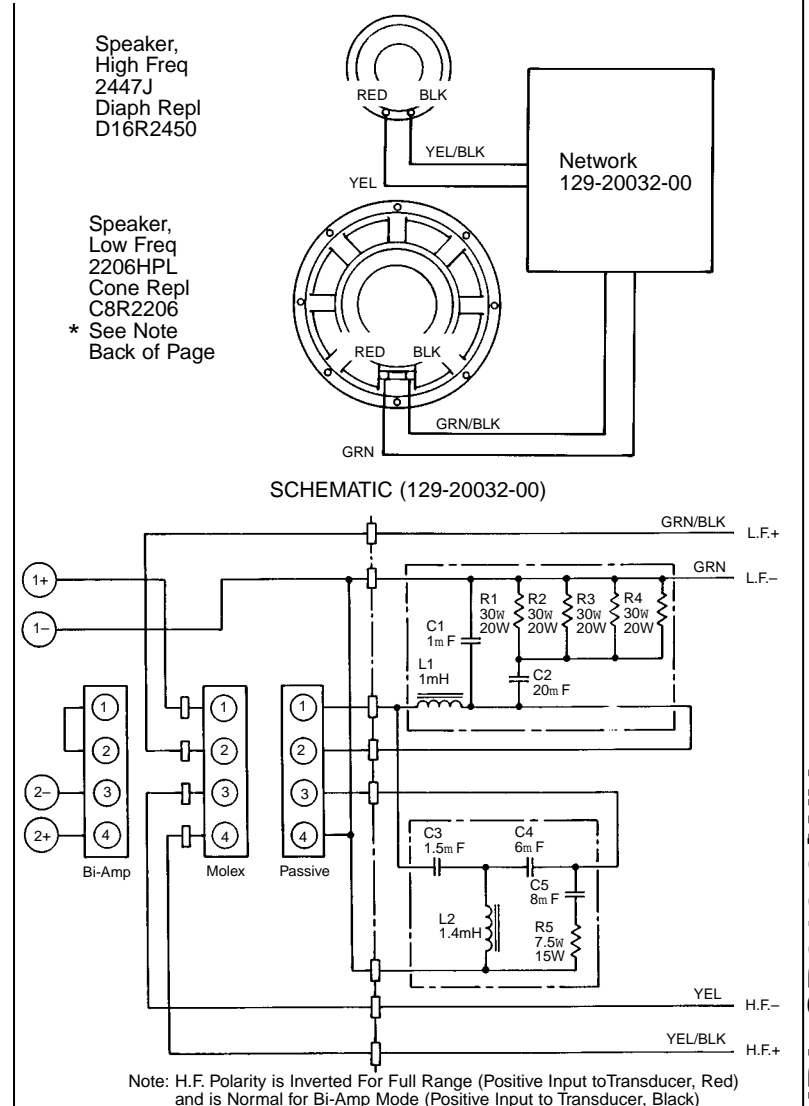

JBL SP212-9/WH REV Q

# JBL SP212-9/WH

## COMPONENT EXPLODED VIEW

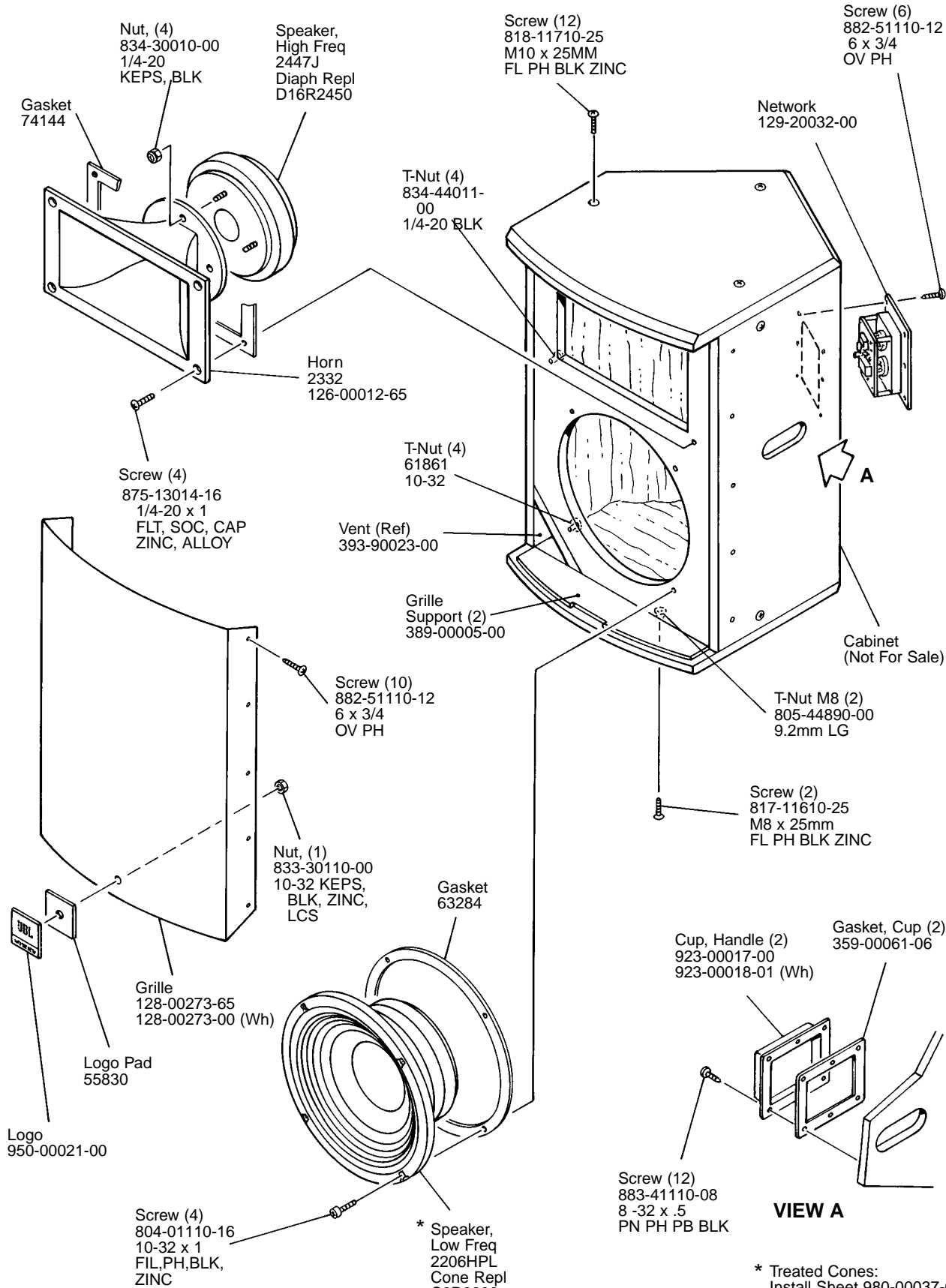

### VIEW A

\* Treated Cones:  
Install Sheet 980-00037-00  
WR2 (2 oz)  
WR16 (16 oz)

NOTE: BLACK DURAFLEX REPAIR KIT 30052      WHITE DURAFLEX REPAIR KIT 30053

JBL SP212-9/WH