

# Technical Manual

# JBL SR4725

## SPECIFICATIONS



### ACOUSTIC & ELECTRICAL SPECIFICATIONS:

- Nominal Impedance: 8 ohm
- Power Rating: 600W
- Frequency Response: 36 Hz to 18 kHz
- Sensitivity: 97 dB SPL\*
- Crossover Frequency: 1.1 kHz

### SYSTEM COMPONENTS:

- Cabinet: CSR4725
- Grille: GSR4725 (71971)
- Low Frequency Transducer: 380mm (15 in.) Paper Cone Transducer (2226H)
- DC Resistance: 5.0 ohm  $\pm$  10% Aluminum Wire

\*1 Watt (2.83 V RMS) @ 1 Meter

### SYSTEM COMPONENTS: (cont'd)

- High Frequency Transducer: 25mm (1 in. Exit) Pure Titanium Compression Driver (2426H)
- DC Resistance: 3.2 ohm  $\pm$  8% Aluminum Wire
- Crossover Network: 71935

### AURAL SWEEP TEST SPECIFICATIONS:

- A. System Aural Sweep Test: 7.0V Input, 20 Hz to 20 kHz
- B. L.F. Aural Sweep Test: 10.0V Input, 20 Hz to 1.2 kHz
- C. H.F. Aural Sweep Test: 2.83V Input, 550 Hz to 20 kHz

### PHYSICAL SPECIFICATIONS:

- Enclosure Dimensions: 724mm x 622mm x 432mm D (28.5 x 24.5 x 17.0 in. D)
- Shipping Weight: 78 lbs. (35.4 kg)

### WARRANTY INFORMATION:

- Refer to the Warranty Statement packed with each product.

## PACKAGE

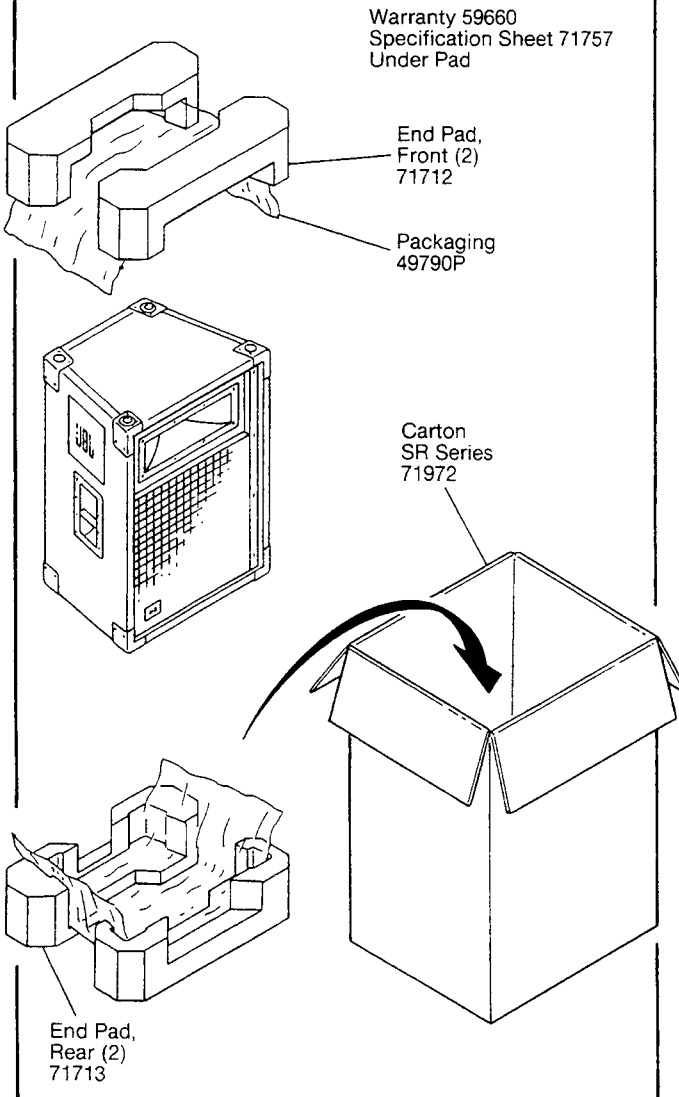

## WIRING DIAGRAM

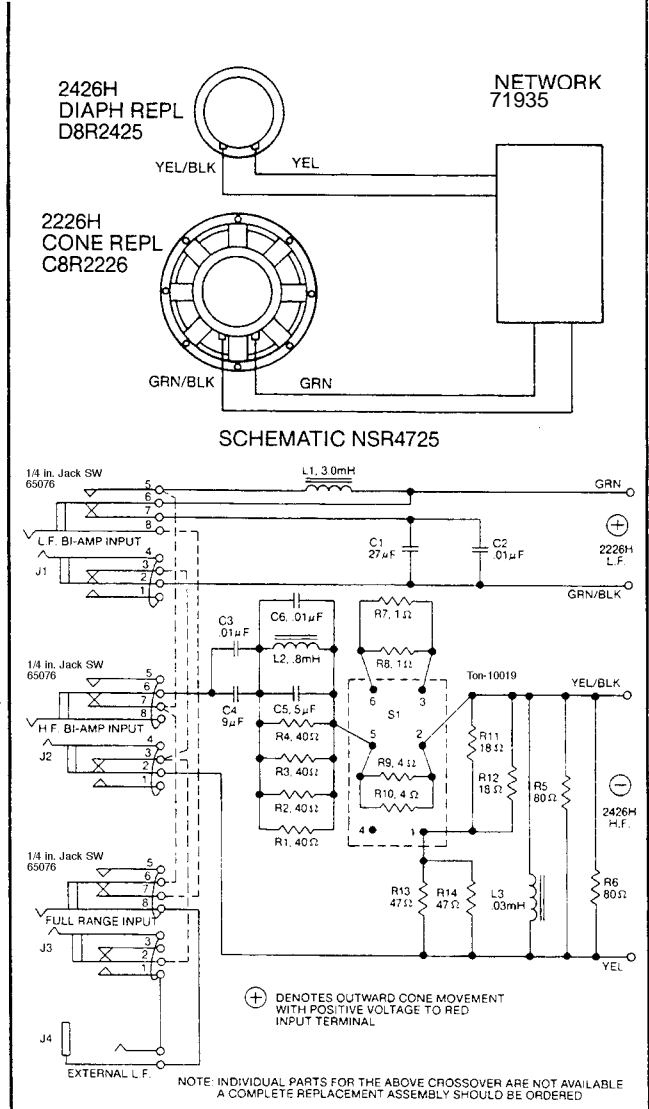

JBL SR4725 REV1

# JBL SR4725

## COMPONENT EXPLODED VIEW

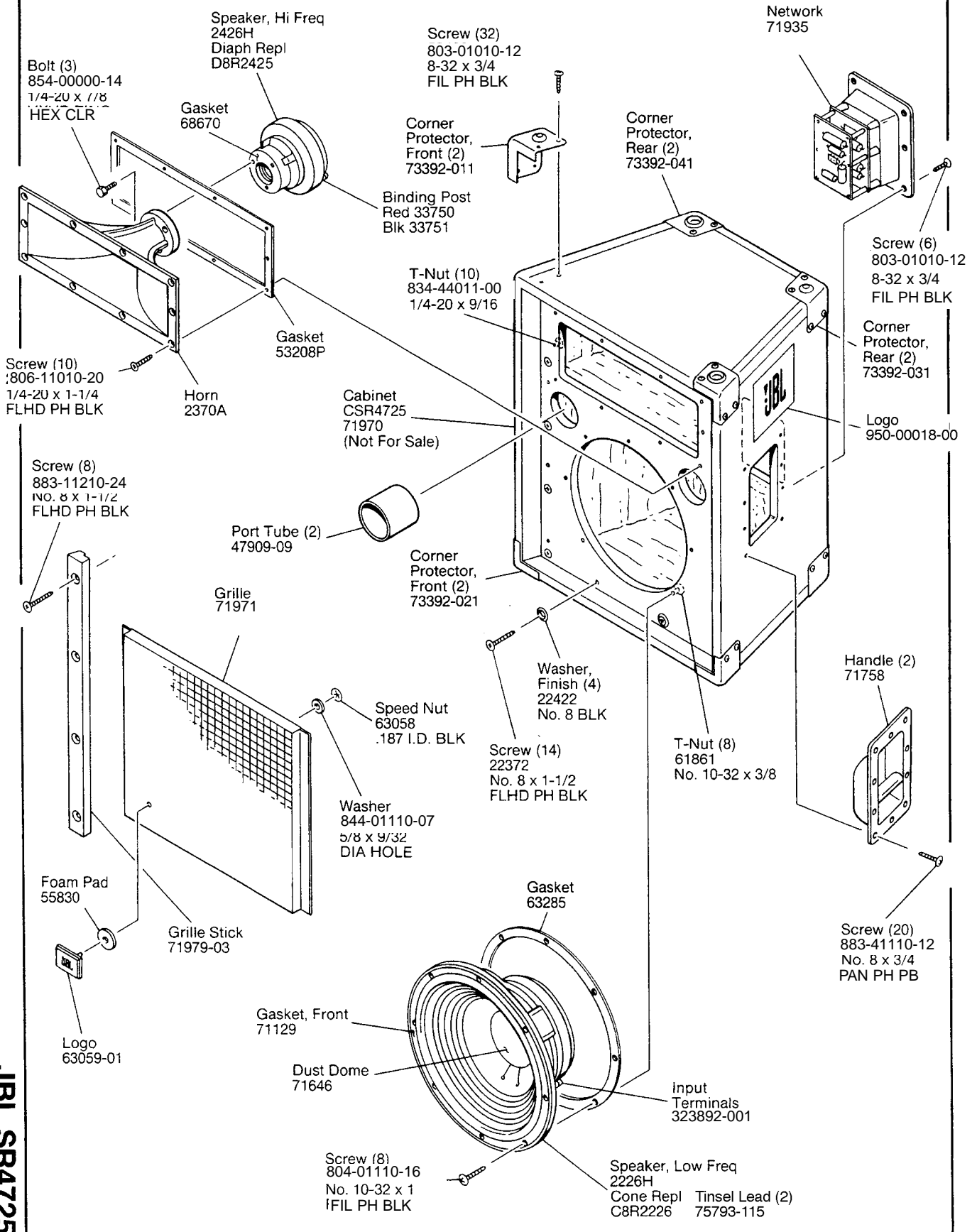

JBL SR4725