

Technical Manual



JBL PD5200/95-WH

SPECIFICATIONS

ACOUSTIC & ELECTRICAL SPECIFICATIONS:

- Nominal Impedance: 8 ohms
- Power Capacity: M.F. 350 W (1400 W Peak), 100 Hrs
300 W (1200 W Peak), 100 Hrs
H.F. 75 W (300 W Peak), 2 Hrs
- Frequency Range: 200 Hz – 17 kHz (–10 dB)
- Sensitivity: M.F. 109 dB SPL (1 W at 1M)
H.F. 114 dB SPL (1 W at 1 M)
- System Sensitivity: Passive Mode 109 dB SPL (1 W at 1 M)
- Passive Crossover: 6th Order (36 dB/Oct) Linkwitz-Riley
HP and LP, 1.5 kHz

SYSTEM COMPONENTS:

- Cabinet: (Not For Sale)
- Grille: 352235-001, 352235-003 (Wh)
- Mid Frequency Transducer: 200mm (8 in.) Driver with Dual Voice
Coil Driver (2169H)
- DC Resistance: 4.2 ohm

SYSTEM COMPONENTS: (cont'd)

- High Frequency Transducer: 38mm (1.5 in.) Exit Compression
Driver with 175mm (3 in.)
Voice Coil (2431H)
- DC Resistance: 5.2 ± 0.4 ohms
- Crossover Network: 352610-001

AURAL SWEEP TEST SPECIFICATIONS:

- A. System Aural Sweep Test: 7.0V Input, 40 Hz to 20 kHz
- B. L.F. Aural Sweep Test: 7.0V Input, 20 Hz to 1.2 kHz
- C. H.F. Aural Sweep Test: 2.83V Input, 100 Hz to 1.0 kHz

PHYSICAL SPECIFICATIONS:

- Enclosure Dimensions: 991mm x 673mm x 706mm D
(39.0 x 26.5 x 27.8 in. D)
- Net Weight: 130 lbs. (56.8 kg.)

WARRANTY INFORMATION:

- Refer to Warranty Statement packed with each product.

PACKAGE

Warranty 59660

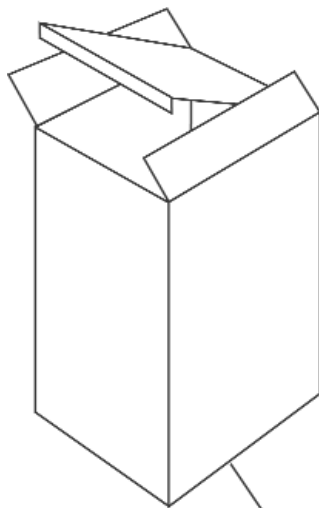

Carton
352163-001

Top and
Bottom Filler
352164-001
Poly Bag
350691-001

WIRING DIAGRAM

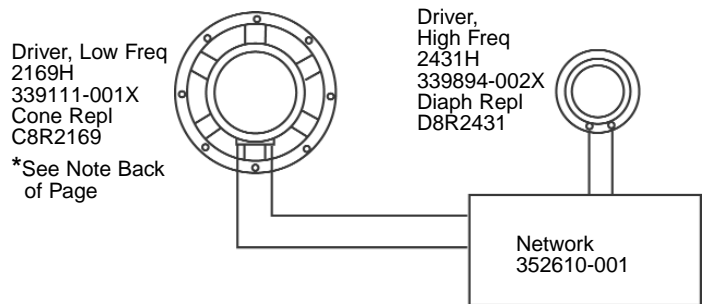

SCHEMATIC (352610-001)

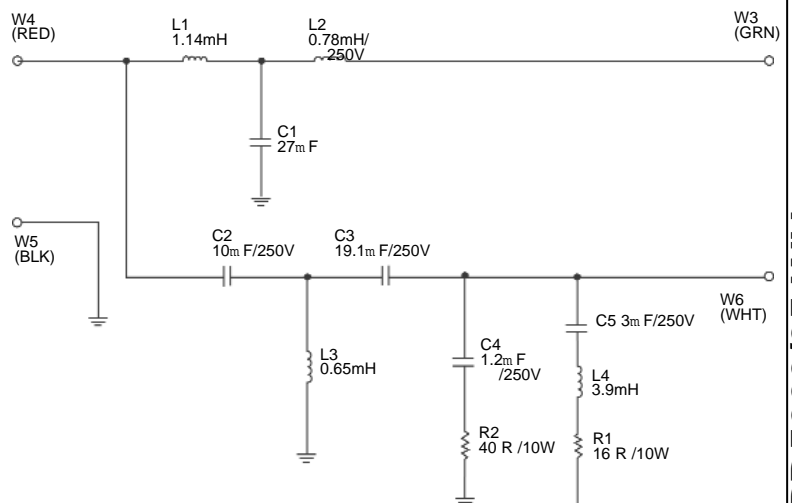

JBL PD5200/95-WH REV F

JBL PD5200/95-WH

COMPONENT EXPLODED VIEW

