

Technical Manual

JBL MS28/WH

SPECIFICATIONS



ACOUSTIC & ELECTRICAL SPECIFICATIONS:

- Nominal Impedance: 16 ohms
- Power Capacity: 200W IEC; 800W Peak
- Frequency Range: 40 Hz – 20 kHz (-10dB)
- Sensitivity: 93 dB SPL, 1 Watt @ 1 Meter
- Crossover Frequency: 2.8 kHz

SYSTEM COMPONENTS:

- Cabinet: (Not For Sale)
- Grille: 128-00343-65, 128-00343-00 (Wh)
- Low Frequency Transducer: 200mm (8 in.) Cone Transducer (508G-3S) (2)
DC Resistance: 5.9 ohm ± 5%
- High Frequency Transducer: 25mm (1 in.) Titanium Diaphragm (2412H)
DC Resistance: 5.3 ohm ± 10%

SYSTEM COMPONENTS: (cont'd)

- Crossover Network/ Terminal Cup: 129-20043-01

AURAL SWEEP TEST SPECIFICATIONS:

- A. System Aural Sweep Test: 10V Input, 20 Hz to 20 kHz
- B. L.F. Aural Sweep Test: 7.0V Input, 20 Hz to 1.2 kHz
- C. H.F. Aural Sweep Test: 2.83V Input, 550 Hz to 20 kHz

PHYSICAL SPECIFICATIONS:

- Enclosure Dimensions: 676mm x 295mm x 324mm D (26.0 x 11.6 x 12.75 in. D)
- Weight: 28 lbs. (12.7 kg.)

WARRANTY INFORMATION:

- Refer to Warranty Statement packed with each product.

PACKAGE

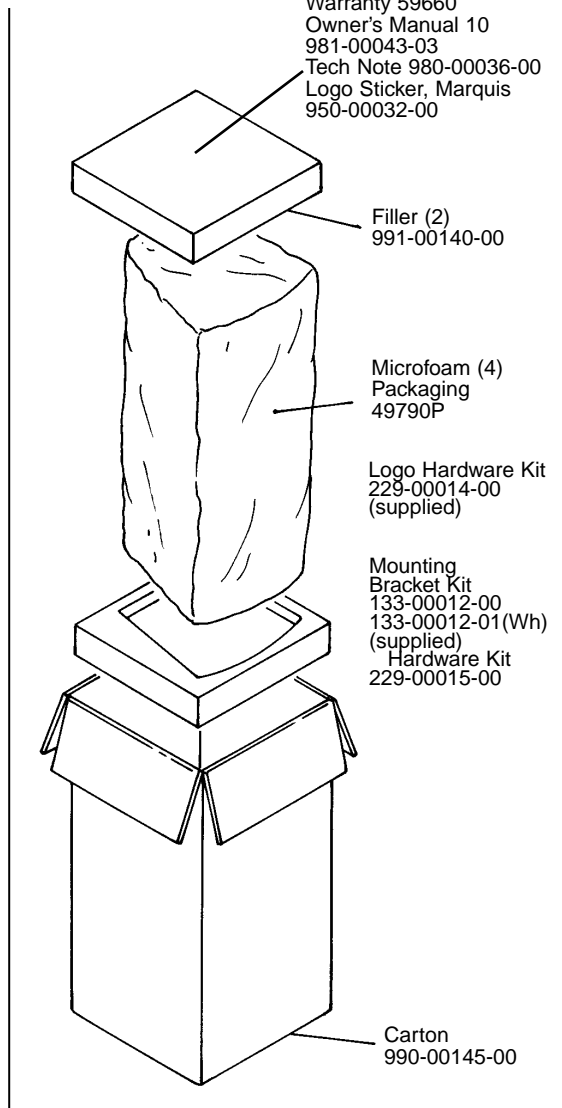

WIRING DIAGRAM

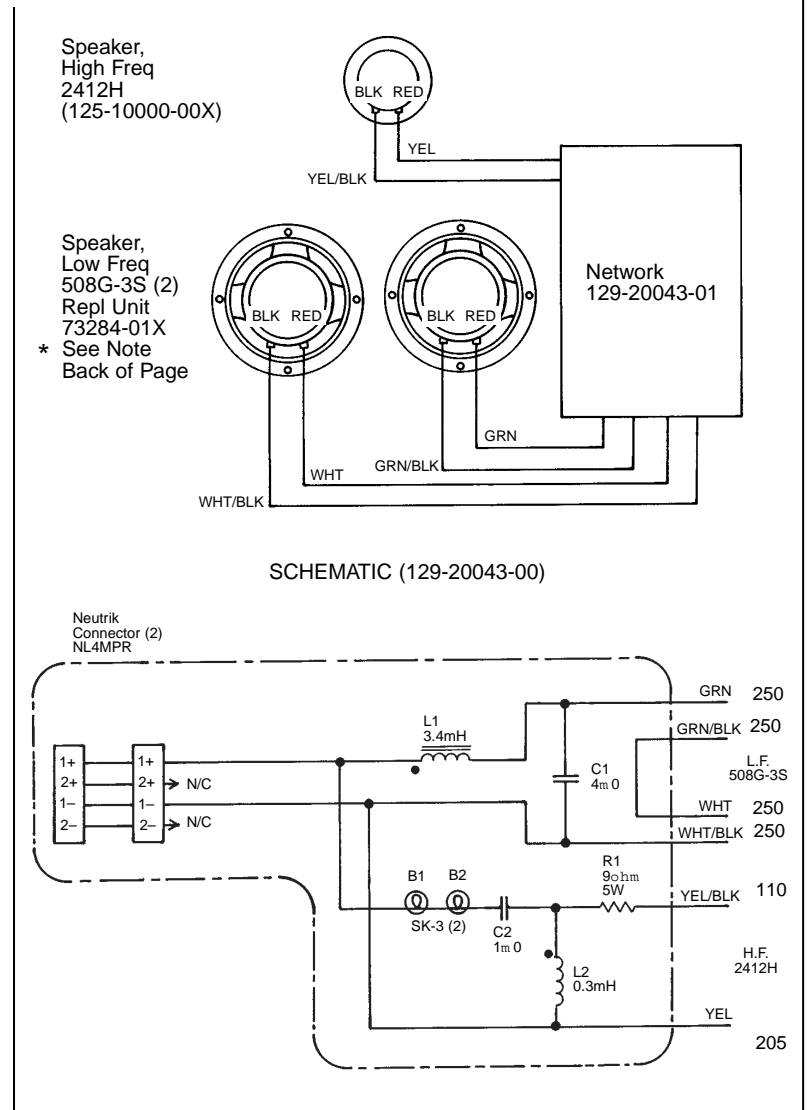

JBL MS28/WH

COMPONENT EXPLODED VIEW

NOTE: BLACK DURAFLEX REPAIR KIT
30052
WHITE DURAFLEX REPAIR KIT
30053

Screw (6)
882-51110-12
6 x 3/4
OV PH

Gasket
359-00110-03

Speaker,
High Freq
2412H
(125-10000-00X)

Network
129-20043-01

Screw (2)
818-11710-25
M10 x 25MM
FL PH BLK ZINC

U-Bracket (supplied)
for installation
133-00012-00

T-Nut, M10 (2)
836-44800-00

Horn
126-00013-00

Screw (12)
882-51110-12
6 x 3/4
OV PH

Screw (4)
803-11110-20
8-32 x 1-1/4
PH FLTHD

Screw (6)
817-11610-25
M8 x 25mm
FL PH BLK ZINC

Grille Stick
Right
389-00019-00
Left
389-00020-00

T-Nut (6)
805-90000-00
M8 x 9.2mm LG

Logo Kit,
Marquis
229-00014-00

Grille
Support (2)
389-00021-00

T-Nut (12)
61860
8-32 x 3/8

Cabinet
(Not For Sale)

Grille
128-00343-65
128-00343-00 (Wh)

Gasket (2)
52671

Screw (8)
803-11010-16
8-32 x 1
FLT, PH, BLK
ZINC, LCS

* Speaker,
Low Freq
508G-3S (2)
Repl Unit
73284-01X

* Treated Cones:
Install Sheet 980-00037-00
WR2 (2 oz)
WR16 (16 oz)