

Technical Manual

JBL MRX525



SPECIFICATIONS

ACOUSTIC & ELECTRICAL SPECIFICATIONS:

- Nominal Impedance: 4 Ohms
- Power Capacity: 800W / 1600W / 3200W, 2 hrs.
(Cont/ Prog/Peak): 700W / 1400W / 2800W, 100 hrs
- Frequency Range: 40 Hz - 20 kHz (-10 dB)
- Frequency Response: 57 Hz – 20 kHz (±3 dB)
- Maximum SPL: 129 dB SPL continuous (135 dB SPL peak)
- System Sensitivity: 100 dB SPL (1 watt @ 1 meter)
- Crossover Frequency: 1.8 kHz

SYSTEM COMPONENTS:

- Cabinet: Enclosure (Not for Sale)
- Grille: 362524-001
- Low Frequency Transducer: 265H-1, 380 mm (15 in) Differential Drive woofer
- DC Resistance: 5.0 ohm ±10%
- High Frequency Transducer: 2408H, 37.5 mm (1.5 in) annular polymer diaphragm, neodymium compression driver
- DC Resistance: 4.8 ohm +/- 0.2 ohm

SYSTEM COMPONENTS:(CONT'D)

- Crossover Network: 364966-001

AURAL SWEEP TEST SPECIFICATIONS:

- A. System Aural Sweep Test: 7.0V Input, 50 Hz to 20 kHz
- B. L.F. Aural Sweep Test: 7.0V Input, 10 Hz to 300 Hz
- C. H.F. Aural Sweep Test: 0.75V Input, 200 Hz to 1.5 kHz

PHYSICAL SPECIFICATIONS:

- Enclosure Dimensions: 1240 x 535 x 460 mm D
(H x W x D) (48.75 x 21.0 x 18.0 in D)
- Net Weight (ea): 84.0 lb (38.2 kg)

WARRANTY INFORMATION:

- Refer to Warranty Statement packed with each product.

PACKAGE

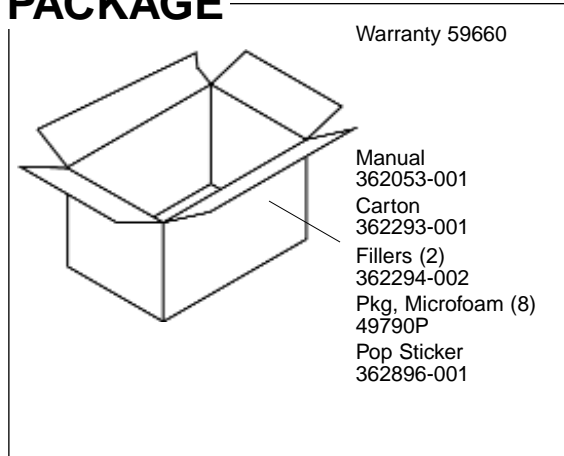

WIRING DIAGRAM

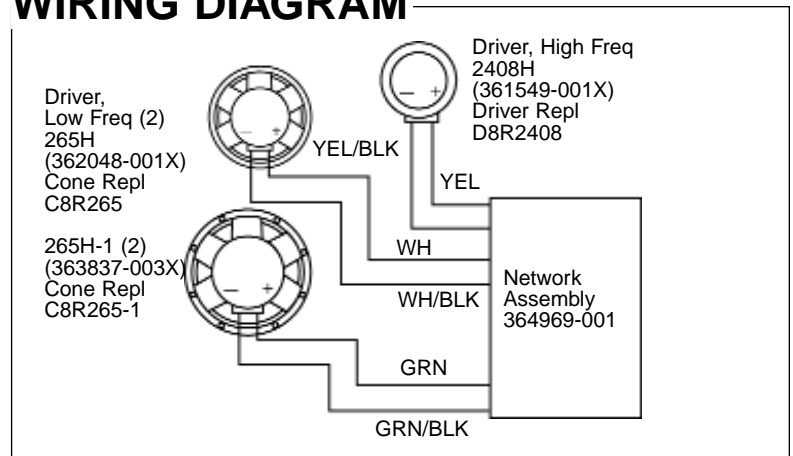

NETWORK SCHEMATIC - (364969-001)

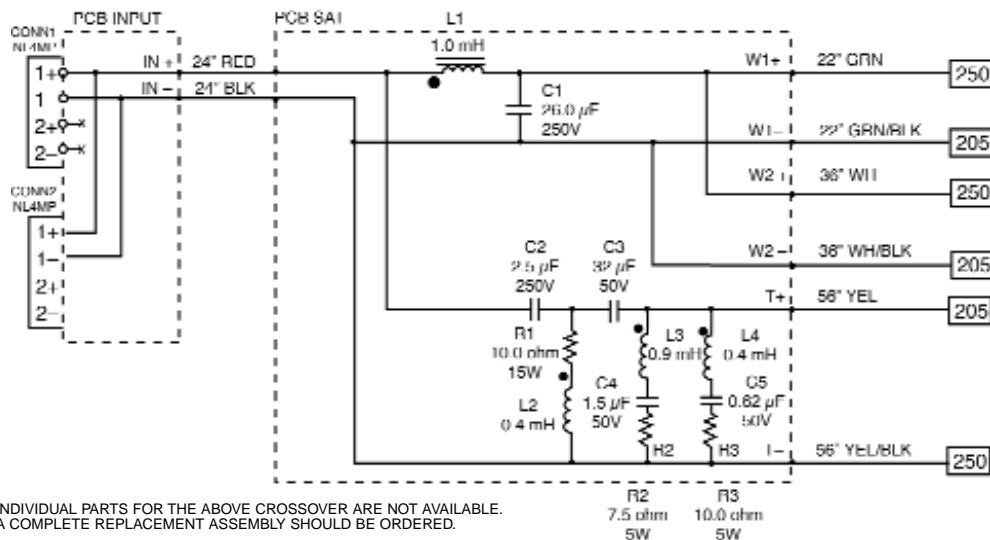

NOTE: INDIVIDUAL PARTS FOR THE ABOVE CROSSOVER ARE NOT AVAILABLE. A COMPLETE REPLACEMENT ASSEMBLY SHOULD BE ORDERED.

JBL MRX525

COMPONENT EXPLODED VIEW

Note: Black Duraflex repair kit 30052

Screw (8)
884-11110-12
10 x 3/4, FLT, PH,
PB, BLK ZINC, LCS

Horn
354267-001

Driver, High Freq
2408H
(361549-001X)
Diaph Repl
D8R2408

Handle Assy (2)
362328-001

Gasket
362056-001

Enclosure Assembly MRX525
(Not for Sale)

Gasket (2)
363125-001

Screw (8)
804-41110-12
10-32 x 3/4, PAN,
PH, BLK ZINC, LCS

T-Nut
61861 (32)
10-32x7/16
Step Barrel

Screw (8)
804-11110-16
10-32 x 1, FLT, PH,
BLK OXIDE, LCS

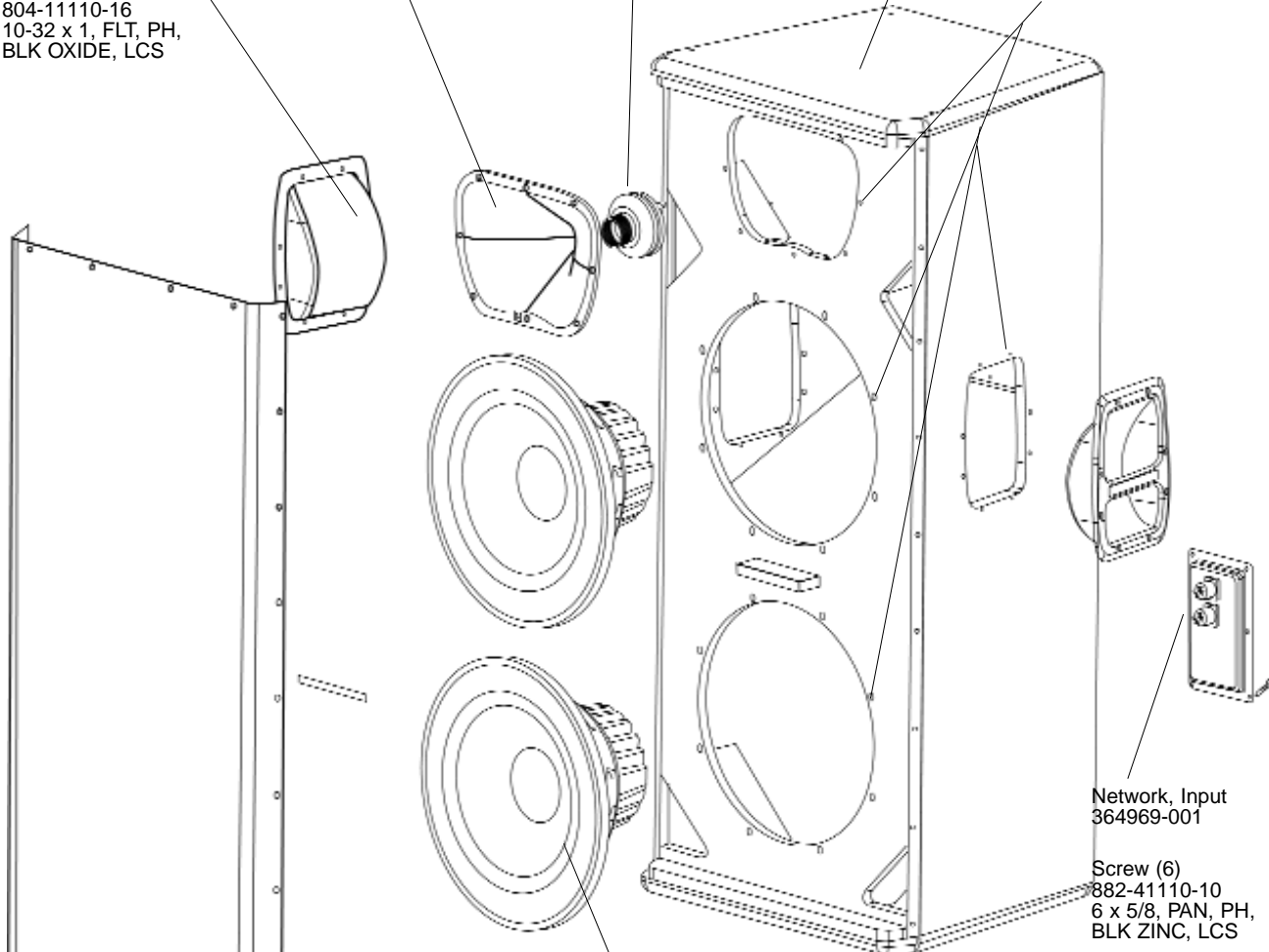

Network, Input
364969-001

Screw (6)
882-41110-10
6 x 5/8, PAN, PH,
BLK ZINC, LCS

Nameplate
362051-001

Grille Assembly w/
Screen
362524-001
Screw (26)
882-51110-12
6 x 3/4, OV, PH, PTCL
BLK ZINC, LCS
Screw
905901-012
#8 x 0.75, BLK

Network, Input
362292-001
Screw (2)
882-41110-10
6 x 5/8, PAN, PH,
BLK ZINC, LCS

Driver, Low Freq (2)
265H
(362048-001X)
Cone Repl
C8R265

265H-1
(363837-003X)
Cone Repl
C8R265-1

Gasket (2)
360-70002-01
Screw (16)
804-01110-16
10-32 x 1, FIL, PH, BLK ZINC, LCS

Foot (4)
353445-001
Screw (4)
884-41110-12
10 x 3/4, PAN, PH,
PB, BLK ZINC, LCS