

# Technical Manual

# JBL MR825

## SPECIFICATIONS



### ACOUSTIC & ELECTRICAL SPECIFICATIONS:

- Nominal Impedance: 8 ohm
- Power Capacity: Continuous Pink Noise: 250W  
Peak Pink Noise: 1000W
- Frequency Range: 60 Hz to 20 kHz ( $\pm 10$ dB)
- Sensitivity: 101 dB SPL\*
- Crossover Frequencies: 1.5 kHz

### SYSTEM COMPONENTS:

- Cabinet: CMR825
- Grille: GMR825 (73232)
- Low Frequency Transducer: 380mm (15 in.) Cone Transducer 2032H (318219-001X)
- DC Resistance: 4.25 ohm  $\pm 10\%$  - Aluminum Wire

### SYSTEM COMPONENTS: (cont'd)

- High Frequency Transducer: 25mm (1 in.) Pure Titanium Compression Driver 2416H-1
- DC Resistance: 3.2 ohm  $\pm 8\%$  - Aluminum Wire
- Crossover Network: 73233-01

### AURAL SWEEP TEST SPECIFICATIONS:

- A. System Aural Sweep Test: 7.0V Input, 20 Hz to 20 kHz
- B. L.F. Aural Sweep Test: 7.0V Input, 20 Hz to 1.5 kHz
- C. H.F. Aural Sweep Test: 2.83V Input, 550 Hz to 20 kHz

### PHYSICAL SPECIFICATIONS:

- Enclosure Dimensions: 667mm x 495mm x 337mm D (26.25 x 19.5 x 13.25 in. D)
- Shipping Weight: 62 lbs. (28.2 kg)

### WARRANTY INFORMATION:

- Refer to the Warranty Statement packed with each product.

\*1 Watt (2.83 V RMS) @ 1 Meter

## PACKAGE

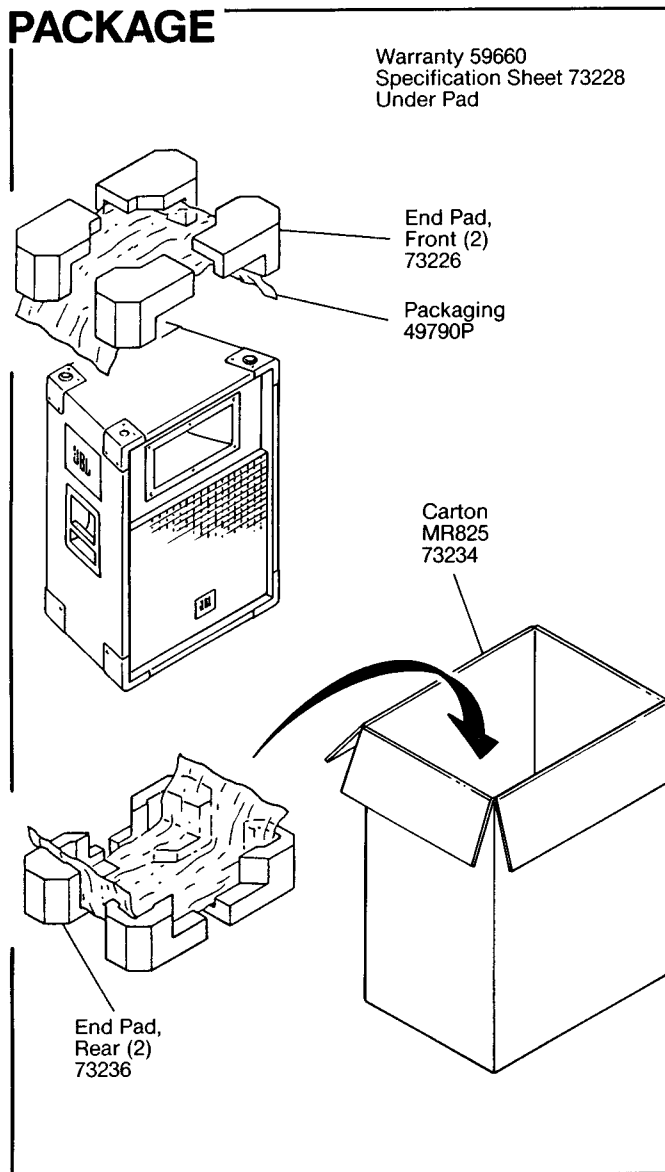

## WIRING DIAGRAM

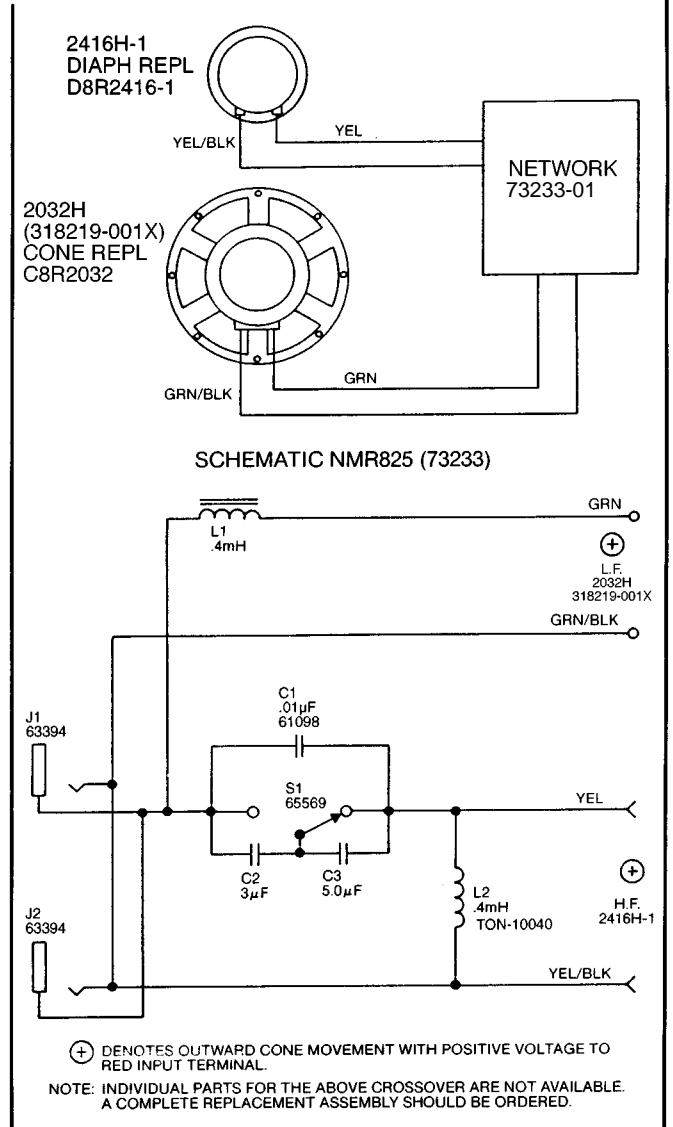

JBL MR825 REV N

