

Technical Manual

JBL MR822

SPECIFICATIONS



ACOUSTIC & ELECTRICAL SPECIFICATIONS:

- Nominal Impedance: 8 ohm
- Power Capacity: Continuous Pink Noise: 250W
Peak Pink Noise: 1000W
- Frequency Range: 60 Hz to 20 kHz (± 10 dB)
- Sensitivity: 100 dB SPL*
- Crossover Frequencies: 2 kHz

SYSTEM COMPONENTS:

- Cabinet: CMR822
- Grille: GMR822 (73223)
- Low Frequency Transducer: 300mm (12 in.) Cone Transducer 2022H
- DC Resistance: 4.65 ohm $\pm 10\%$ - Aluminum Wire

*1 Watt (2.83 V RMS) @ 1 Meter

SYSTEM COMPONENTS: (cont'd)

- High Frequency Transducer: 25mm (1 in.) Pure Titanium Compression Driver 2416H-1
- DC Resistance: 3.2 ohm $\pm 8\%$ - Aluminum Wire
- Crossover Network: NMR822 (73224)

AURAL SWEEP TEST SPECIFICATIONS:

- A. System Aural Sweep Test: 7.0V Input, 20 Hz to 20 kHz
- B. L.F. Aural Sweep Test: 7.0V Input, 20 Hz to 1.2 kHz
- C. H.F. Aural Sweep Test: 2.83V Input, 550 Hz to 20 kHz

PHYSICAL SPECIFICATIONS:

- Enclosure Dimensions: 590mm x 432mm x 279mm D (23.25 x 17.0 x 11.0 in. D)
- Shipping Weight: 55 lbs. (24.5 kg)

WARRANTY INFORMATION:

- Refer to the Warranty Statement packed with each product.

PACKAGE

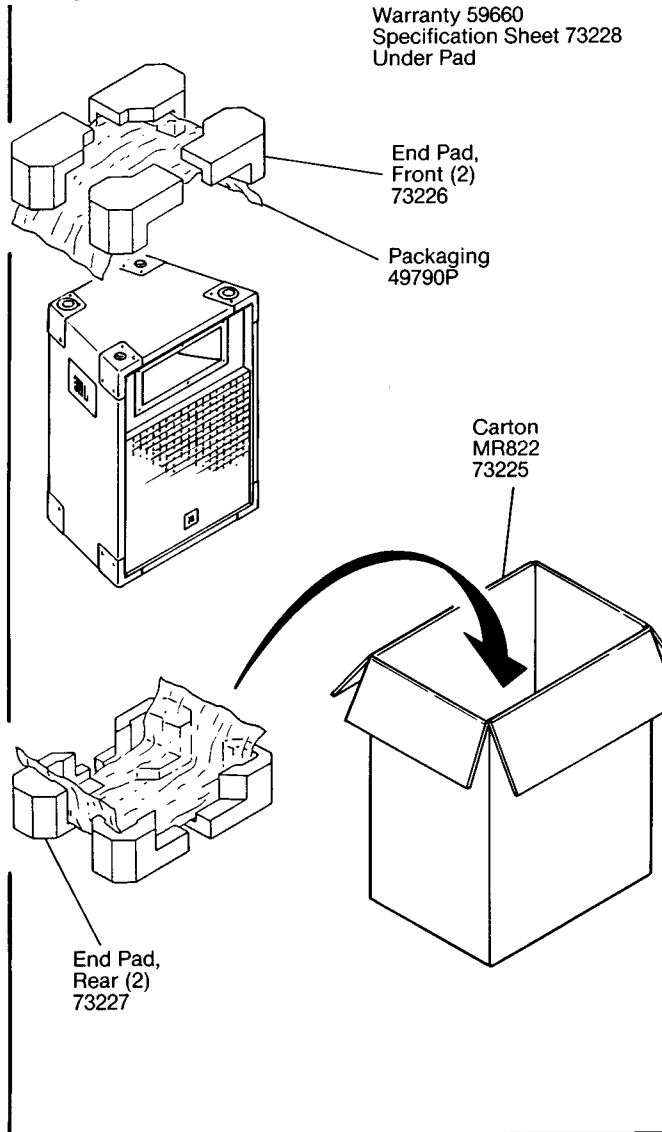

WIRING DIAGRAM

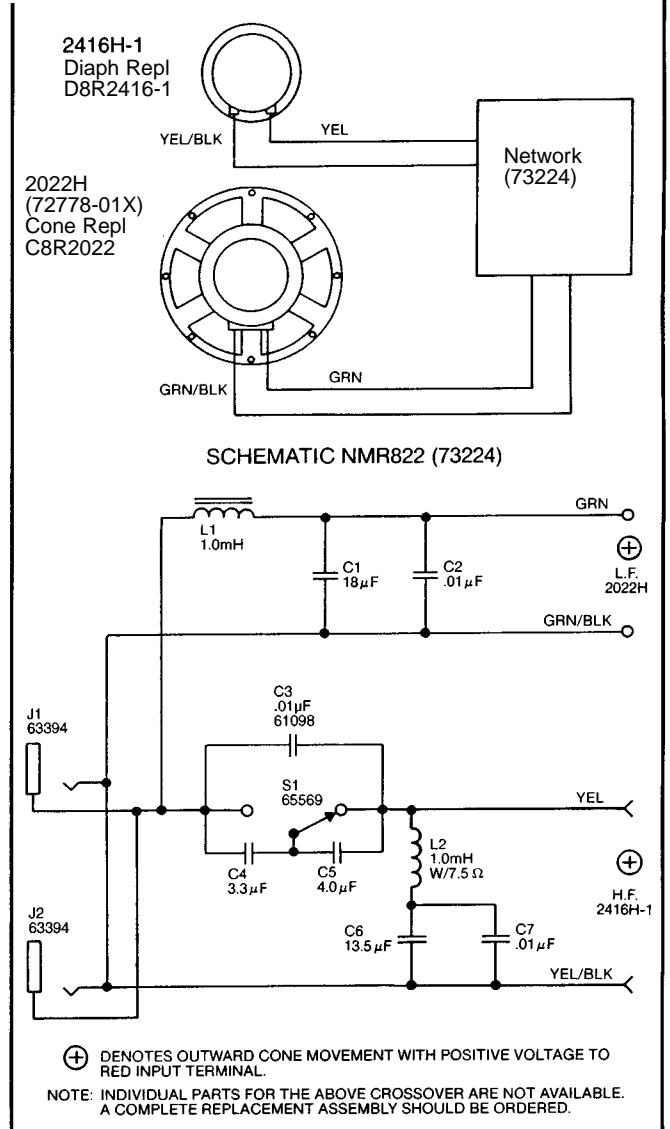

JBL MR822 REV L

JBL MR822

COMPONENT EXPLODED VIEW

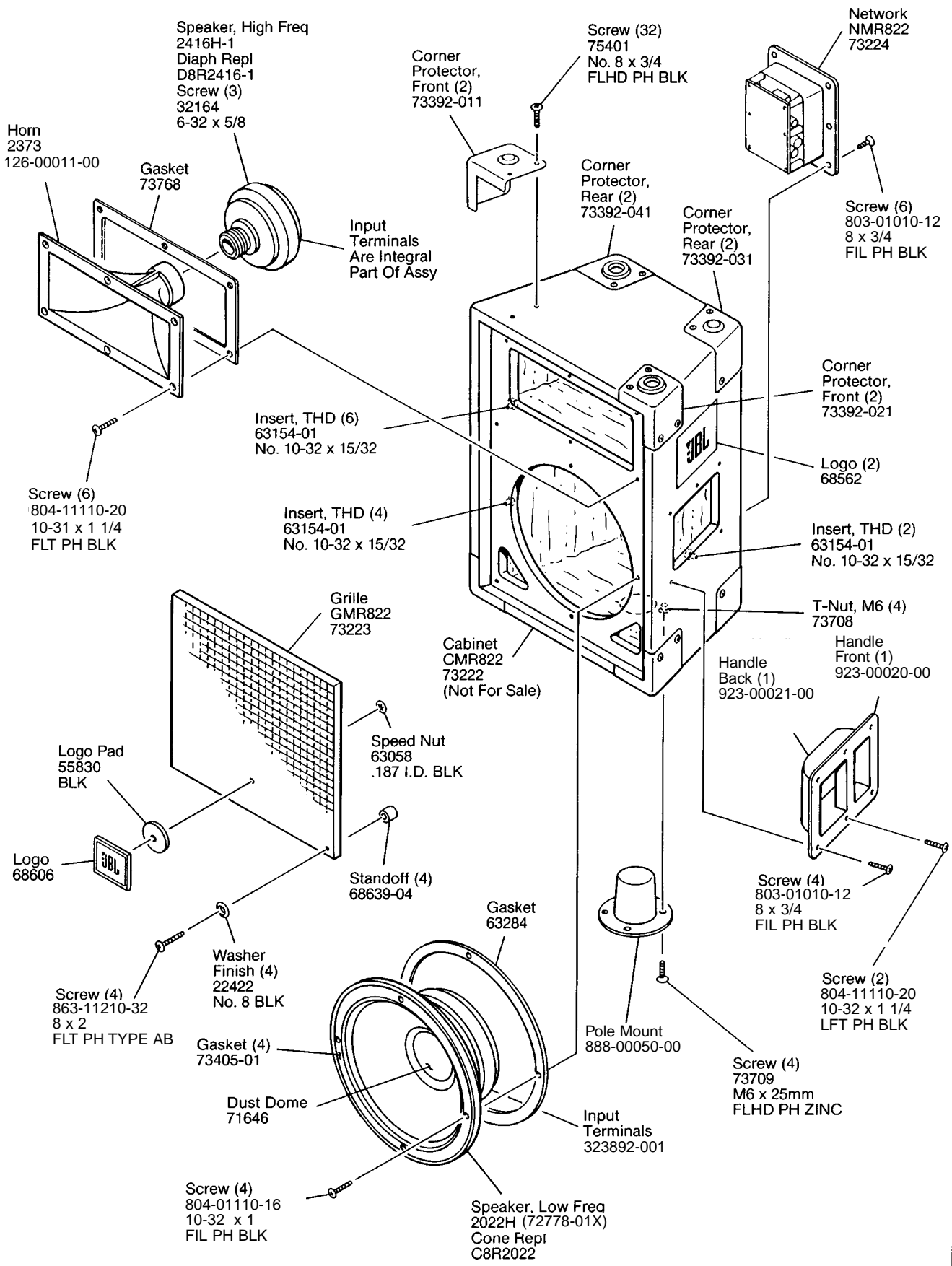

JBL MR822