

Technical Manual

JBL JRX115i

SPECIFICATIONS



ACOUSTIC & ELECTRICAL SPECIFICATIONS:

- Nominal Impedance: 8 Ohms
- Power Capacity: 250W, Peak Power Capacity 1000W
- Frequency Range: 38 Hz – 16 kHz (-10dB)
- Sensitivity: 98 dB, 1Watt @ 1 Meter
- Crossover Frequency: 1.6 kHz

SYSTEM COMPONENTS:

- Cabinet: Enclosure (Not for Sale)
- Grille: 352946-001
- Low Frequency Transducer: M115-8A, 380mm (15 in.) Cone Transducer
- DC Resistance: 5.3 ohms
- High Frequency Transducer: 2412H-1, 25.4mm (1 in.) Exit Compression Driver 2412H-1

SYSTEM COMPONENTS: (CONT'D)

- DC Resistance: 4.3 ohms
- Crossover Network: 364247-001

AURAL SWEEP TEST SPECIFICATIONS:

- A. System Aural Sweep Test: 7.0V Input, 20 Hz to 20 kHz
- B. L.F. Aural Sweep Test: 7.0V Input, 20 Hz to 1.2 kHz
- C. H.F. Aural Sweep Test: 2.83V Input, 500 Hz to 20 kHz

PHYSICAL SPECIFICATIONS:

- Enclosure Dimensions: 698.5 x 459.9 x 431.8 mm D (27.5 x 18.11 x 17.0 in.D)
- Shipping Weight: 67.0 lb (30.4 kg.)

WARRANTY INFORMATION:

- Refer to Warranty Statement packed with each product.

PACKAGE

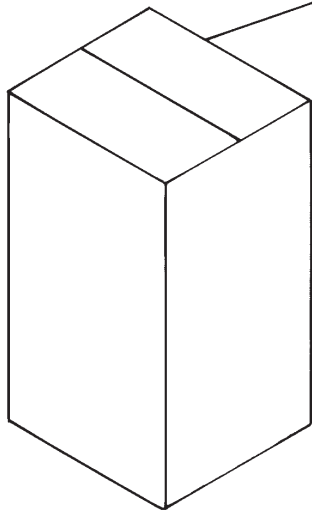

Warranty 59660
User Guide, 352934-001

Carton
365164-001
Pad (2)
351892-001

Filler (2)
339021-001

PKG, Microfoam (5)
49790P
29" x 18" sheets

Rigging
Hardware Kit
229-00009-01

WIRING DIAGRAM

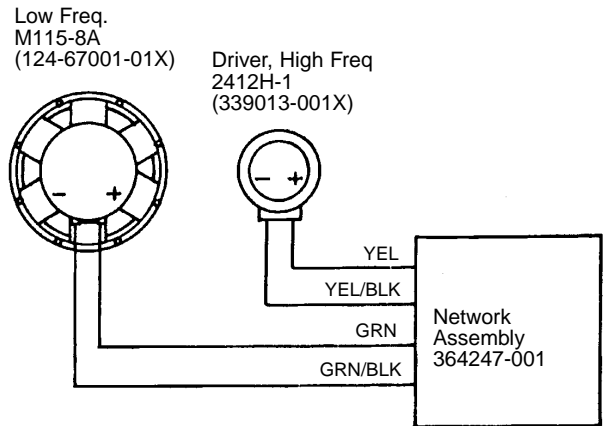

NETWORK SCHEMATIC - (364247-001)

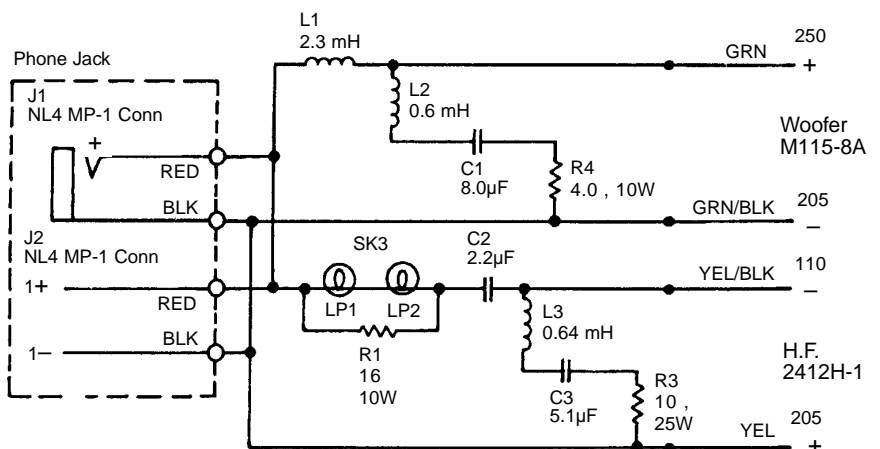

JBL JRX115i

COMPONENT EXPLODED VIEW

