

Technical Manual



JBL CBT 100LA/WH/-1 SPECIFICATIONS

ACOUSTIC & ELECTRICAL SPECIFICATIONS:

- Nominal Impedance: 8 Ohms (in Thru mode)
- Power Capacity: 325W (1300W peak), 2 hrs
(8 ohm setting): 200W (800W peak), 100 hrs
- Frequency Range: 80 Hz - 20 kHz (-10 dB)
- Maximum SPL:
 - Narrow:(speech mode): 121 dB cont ave (127 peak)
 - (music mode): 118 dB cont ave (124 peak)
- Board: (speech mode): 118 dB cont ave (124 peak)
- (music mode): 115 dB cont ave (121 peak)
- Sensitivity: (2.83V @ 1 meter)
 - Narrow: (speech mode): 96 db (2 kHz -14 kHz)
 - (music mode): 93 dB (300 Hz - 18 kHz)
 - Board: (speech mode): 93 dB (2 kHz -14 kHz)
 - (music mode): 90 dB (300 Hz - 18 kHz)

SYSTEM COMPONENTS: (CONT'D)

- Grille: 442866-001, 442866-002 (WH)
- Components / Driver: Sixteen 50 mm (2 in) Full-Range
- DC Resistance: 10.0 ohms
- Crossover Network: 442869-001 (Main PCB)

AURAL SWEEP TEST SPECIFICATIONS:

- A. System Aural Sweep Test: 5.0V Input, 20 Hz to 1000 Hz
- Sweep duration: 10 seconds

PHYSICAL SPECIFICATIONS:

- Enclosure Dimensions: 1000 x 98.5 x 153 mm D
(39.4 x 3.8 x 6.0 in.D.)
- Net Weight: 15.8 lb (7.2 kg)

WARRANTY INFORMATION:

- Refer to Warranty Statement packed with each product.

70V/100V Transformer Taps: 100W, 50W, 30W, (15W at 70V only), and 8Ω thru, via switch

SYSTEM COMPONENTS:

- Cabinet: Enclosure (Not for Sale)

PACKAGE

Warranty
59660

Specification Sheet
444195-001
5011376 (-1 Series)

Owners Manual
442818-001
5011372 (-1 Series)

Filler, Top (2)
442862-001

Filler, Bottom (2)
444186-001

Filler, Middle (2)
444185-001

Label (-1 Series)
5011375
5011377 (WH)

Pearl Bag
444198-001

Accessories Box / Kit Includes:

- Speaker Bracket
442811-001
442811-002 (WH)
- Wall Bracket
442812-001
442812-002 (WH)
- Bolts (6)
442814-001
442814-002 (WH)
M6-16MM
- Washers, SS Lock (6)
444191-001
444191-002 (WH)
- Washers, Flat SS (6)
444190-001
444190-002 (WH)
- Switch Cover (3)
444192-001
444192-002 (WH)
- Bolts (2)
444478-001
444478-002 (WH)
M6-34MM
- Nuts (2)
444479-001
444479-002 (WH)
M6

Carton
442876-001
5011374 (-1 Series)

Bracket (-1 Series)
Speaker / Wall
445765-001
445765-002 (WH)

JBL CBT 100LA/WH/-1 REV C

JBL CBT 100/LA/WH/-1

SCHEMATIC (442869-001)

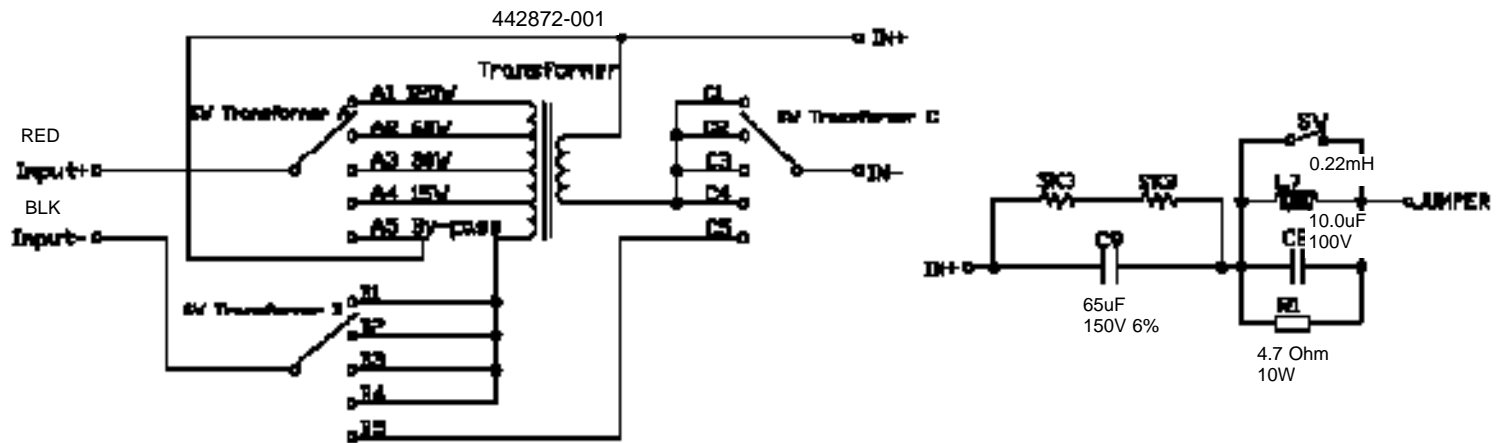
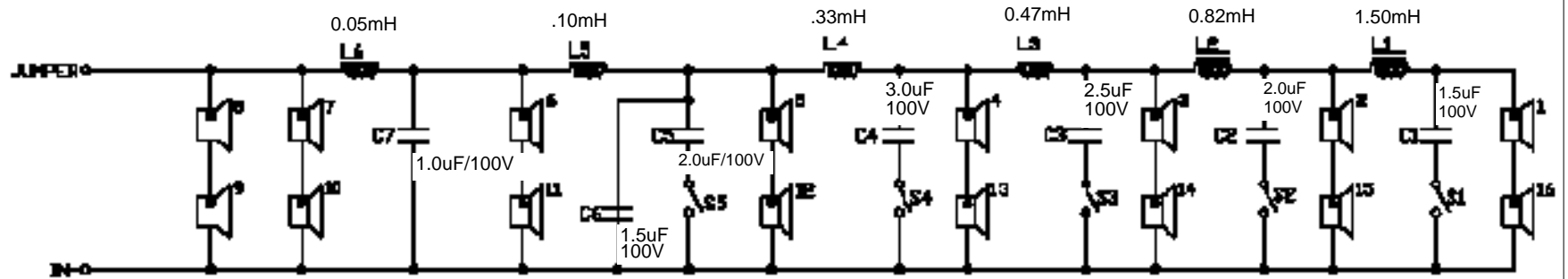

Individual Parts for the above crossover are not available.
A complete replacement assembly should be ordered.

JBL CBT 100/LA/WH/-1

JBL CBT 100LA/WH/-1

COMPONENT EXPLODED VIEW

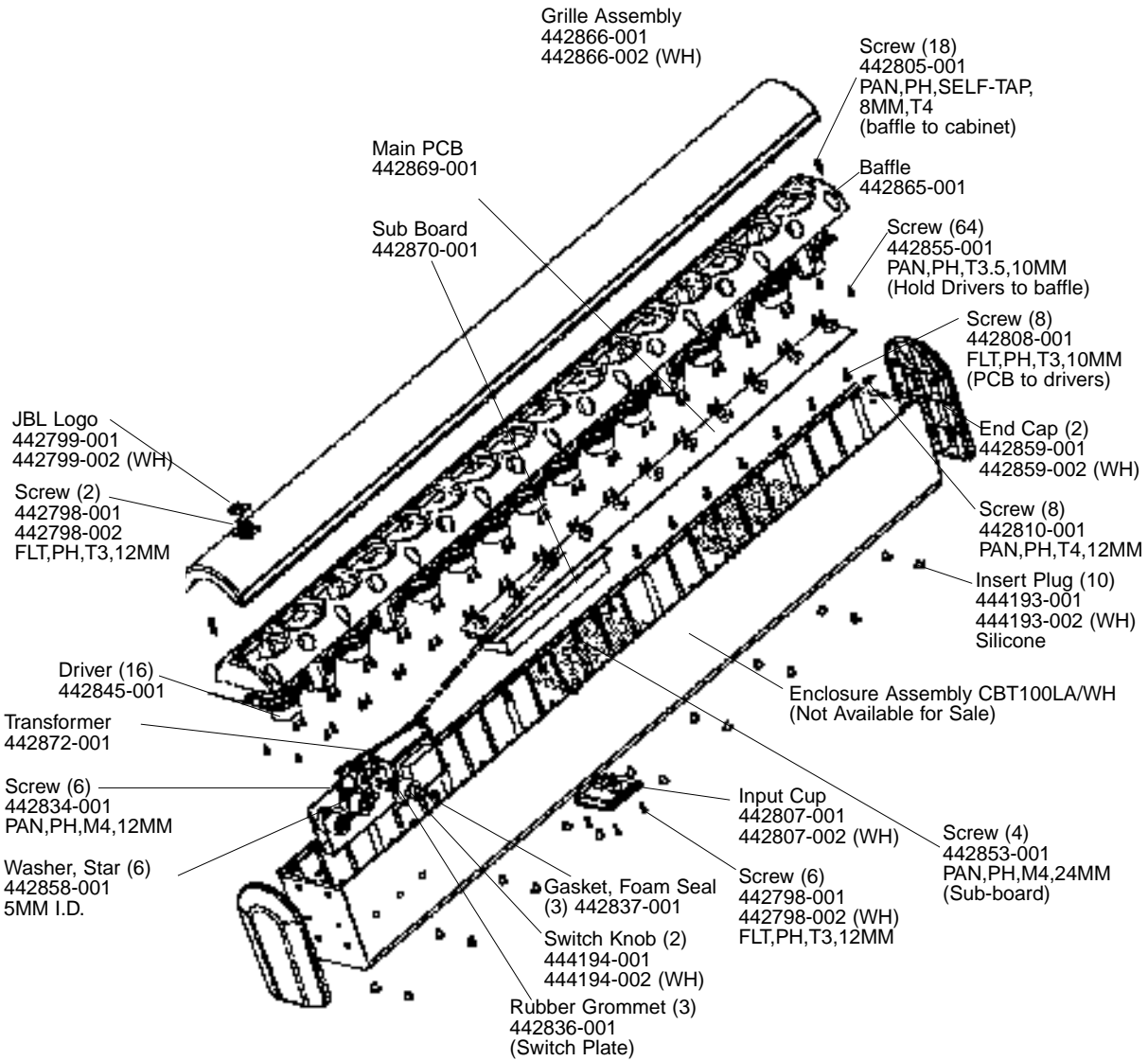

JBL CBT 100LA/WH/-1