

Technical Manual

JBL AM7215/64-WH



SPECIFICATIONS

ACOUSTIC & ELECTRICAL SPECIFICATIONS:

- Nominal Impedance: 8 Ohms
- Transducer Power Rating (AES): LF: 1000W (4000W peak), 2 hrs
750W (3000W peak), 100 hrs
HF: 100W (400W peak), 2 hrs
- Long-Term Power Rating (IEC): Passive mode: 600W (2400W peak)
100 hrs
- Frequency Response: 40 Hz - 18 kHz (± 3 dB)
- Frequency Range: 34 Hz - 20 kHz (-10 dB)
- Maximum SPL: Bi-amp mode: LF: 128 dB-SPL cont avg (134 dB peak)
HF: 135 dB-SPL cont avg (141 dB peak)
Passive mode: 124 dB-SPL cont avg (130 dB peak)
- System Sensitivity: Passive mode: 96 dB SPL
1 watt @ 1 meter
- Passive Crossover Frequency: 1.8 kHz

SYSTEM COMPONENTS:

- Cabinet: Enclosure (Not For Sale)
- Grille: 338163-002, 338163-102 (WH)
- Low Frequency: 2265HPL, 380 mm (15 in)

SYSTEM COMPONENTS: (CONT'D)

- Transducer: Differential Drive®, driver with 75 mm (3 in) dual voice coil
5.10 ohm +/- 10%
- DC Resistance: 2432H, 38 mm (1.5 in) exit compression driver, 75 mm (3 in) voice coil
- High Frequency Transducer: 4.00 ohm +/- 0.2 ohm
- DC Resistance: 444086-001
- Crossover Network: 444086-001

AURAL SWEEP TEST SPECIFICATIONS:

- A. System Aural Sweep Test: 7.0V Input, 20 Hz to 20 kHz
Sweep Duration: 5 seconds
- B. L.F. Aural Sweep Test: 15.0V Input, 10 Hz to 100 Hz
- C. H.F. Aural Sweep Test: 3.0V Input, 300 Hz to 1.0 kHz

PHYSICAL SPECIFICATIONS:

- Enclosure Dimensions: 781 x 420 x 503 mm D
(30.8 x 16.5 x 19.8 in.D.)
- Net Weight: 60 lb (27.2 kg.)

WARRANTY INFORMATION:

- Refer to Warranty Statement packed with each product.

PACKAGE

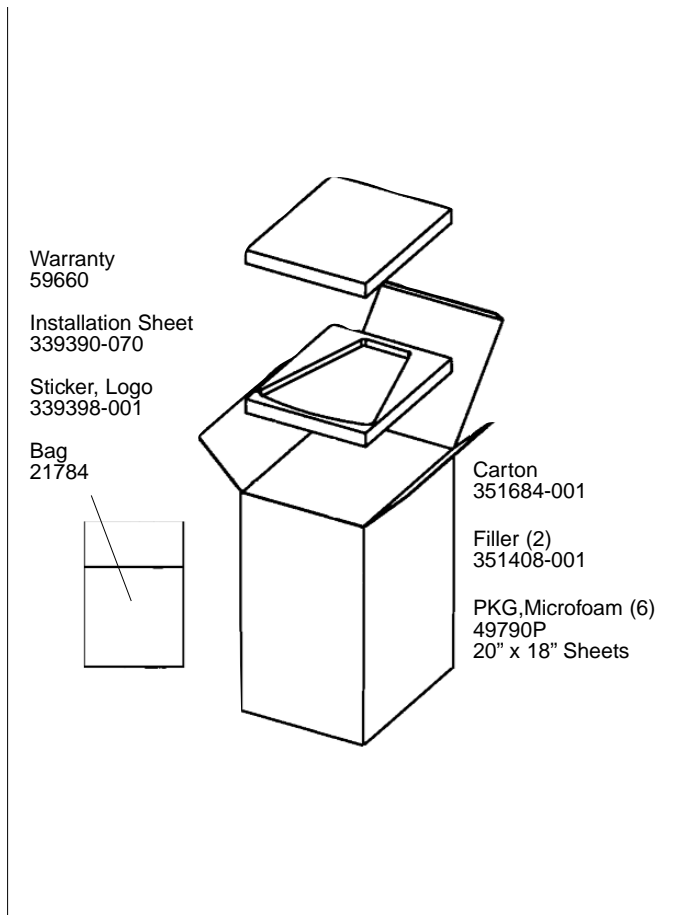

WIRING DIAGRAM

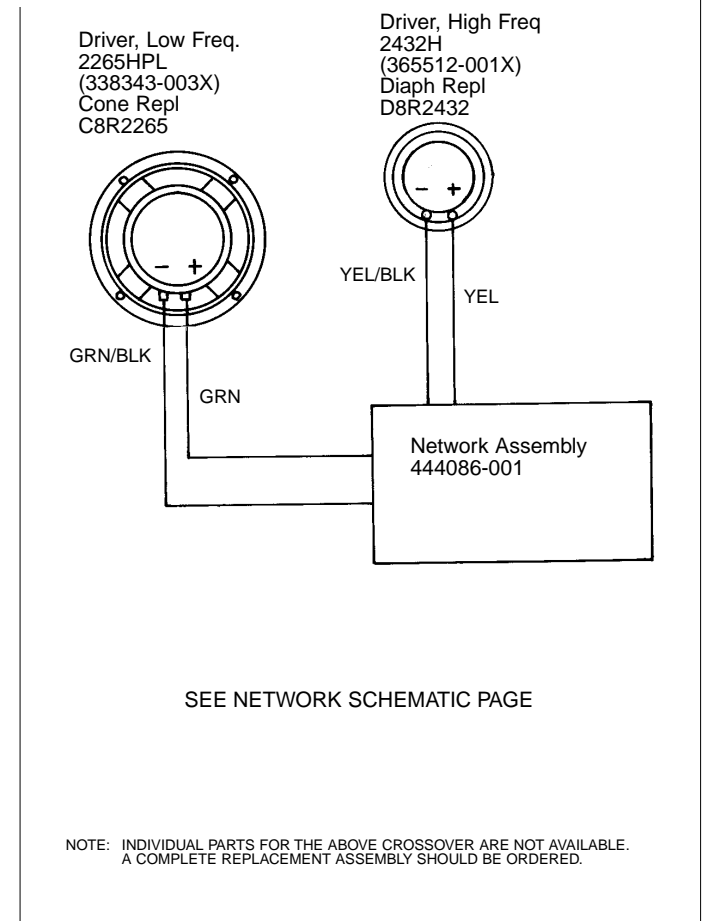

JBL AM7215/64-WH

SCHEMATIC (444086-001)

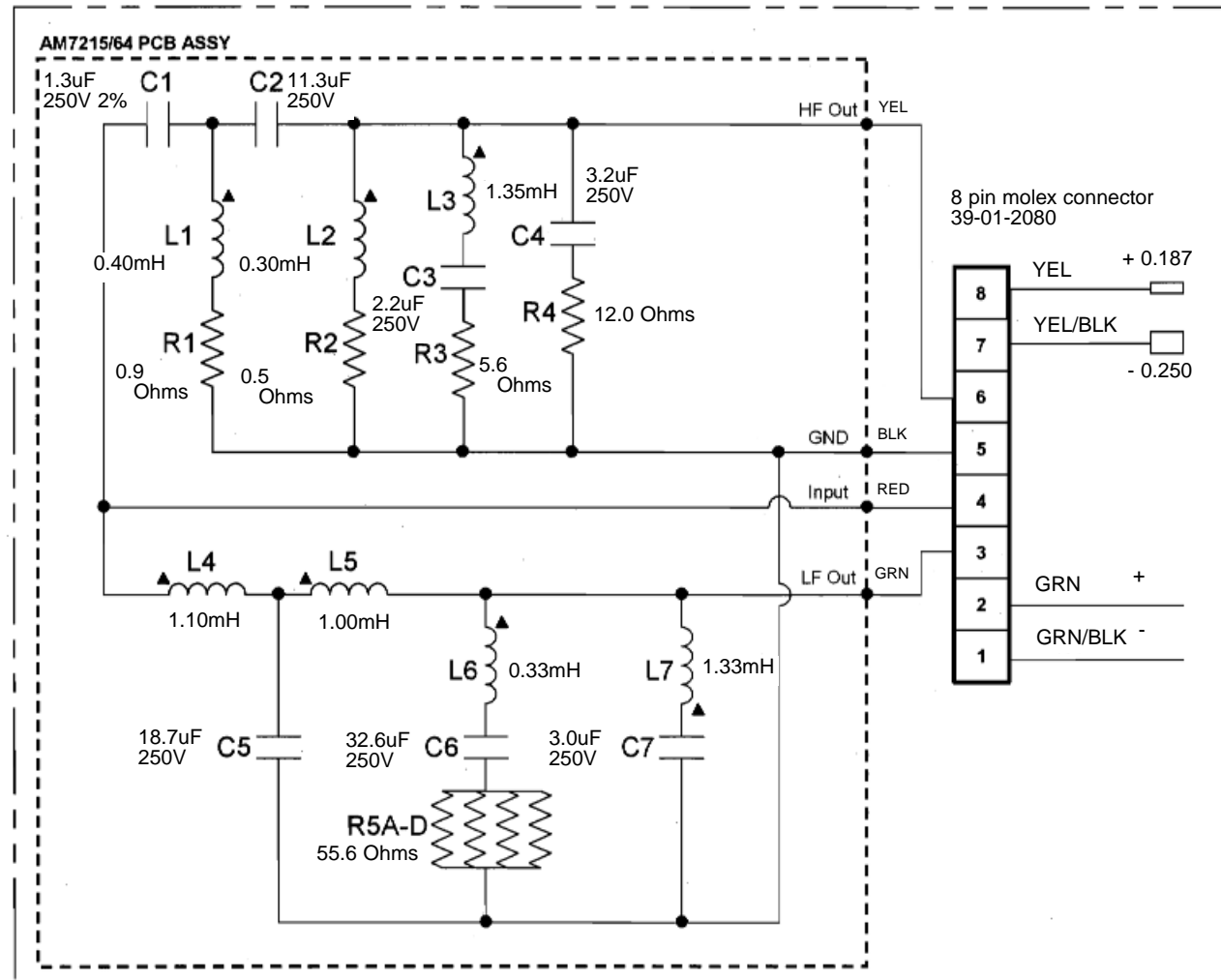

VIEW FROM CONNECTOR PIN SIDE

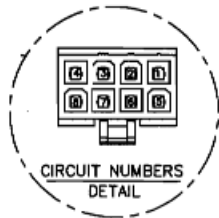

Individual Parts for the above crossover are not available.
A complete replacement assembly should be ordered.

JBL AM7215/64-WH

JBL AM7215/64-WH

COMPONENT EXPLODED VIEW

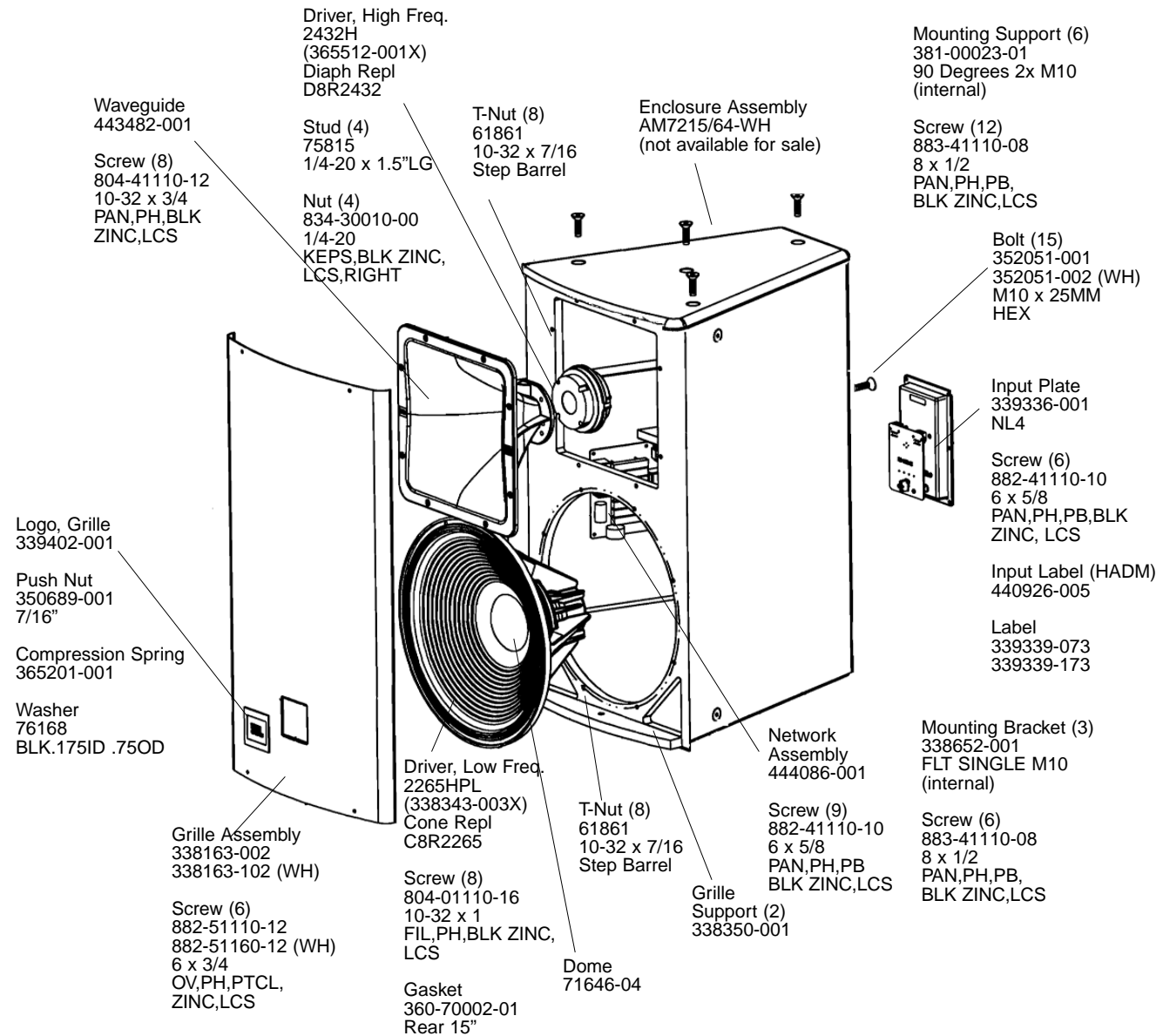

JBL AM7215/64-WH