

# Technical Manual



# JBL AM4315/64-WH

## SPECIFICATIONS

### ACOUSTIC & ELECTRICAL SPECIFICATIONS:

- Nominal Impedance: 8 Ohms
- Power Capacity: 350W
- Frequency Range: 40 Hz – 20 kHz (– 10 dB)
- Sensitivity: 97 dB, 1 Watt @ 1 Meter
- Crossover Frequencies: 2.8kHz

### SYSTEM COMPONENTS:

- Cabinet: Enclosure (Not for Sale)  
Right Panel (338803-002), Left Panel (338803-001), Rear Panel (338805-001), Top/Bottom Panels (338378-001)
- Grille:
- Low Frequency Transducer: 2033H, 380 mm (15 in) driver with 75 mm (3 in) voice coil
- DC Resistance: 5.3 ohms ±10%
- Mid-Frequency Transducer: 165H, 165mm (6.5 in.) diameter internal driver
- DC Resistance: 5.8 ohms ±10%

### SYSTEM COMPONENTS: (CONT'D)

- High Frequency Transducer: 2407H/MTA, 38 mm (1.5 in) Exit Compression Driver, 38 mm (1.5 in) voice coil
- DC Resistance: 4.3 ohms ±10%
- Terminal Cup: 339336-01

### AURAL SWEEP TEST SPECIFICATIONS:

- A. System Aural Sweep Test: 7VRMS Input, 20 Hz to 20 kHz
- B. L.F. Aural Sweep Test: 7VRMS Input, 20 Hz to 5 kHz
- C. M.F. Aural Sweep Test: 5.0VRMS Input, 100 Hz to 5 kHz
- D. H.F. Aural Sweep Test: 2.83VRMS Input, 1.6 kHz to 16 kHz

### PHYSICAL SPECIFICATIONS:

- Enclosure Dimensions: 947 x 561 x 657 mm D (38.1 x 22.1 x 25.9 in.D.)
- Shipping Weight: 103 lb (46.7 kg.)

### WARRANTY INFORMATION:

- Refer to Warranty Statement packed with each product.

## PACKAGE

Warranty 59660

Installation Sheet  
339390-030

Model Label WH  
339339-127

Model Label BLK  
339339-027

Sticker, JBL  
337638-001

Logo Sticker grille  
339399-001

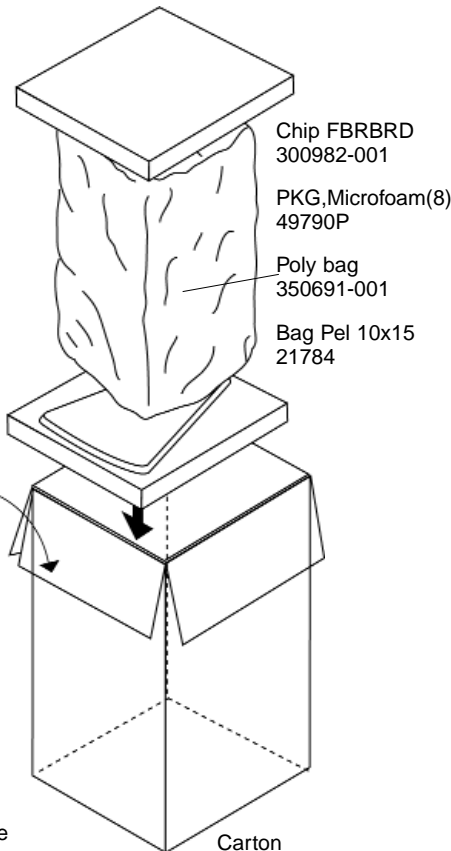

## WIRING DIAGRAM

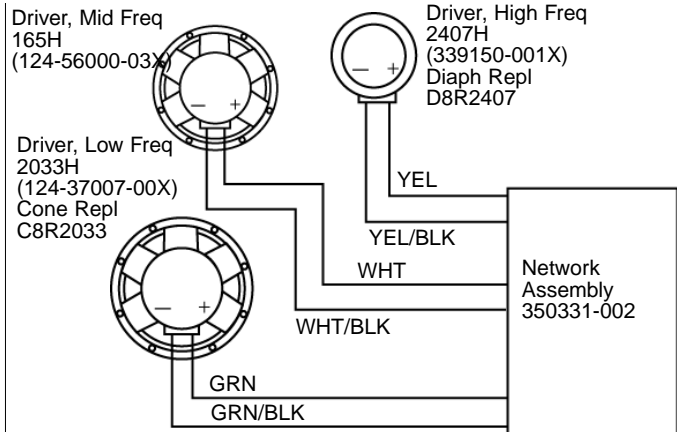

NETWORK SCHEMATIC: 350331-002

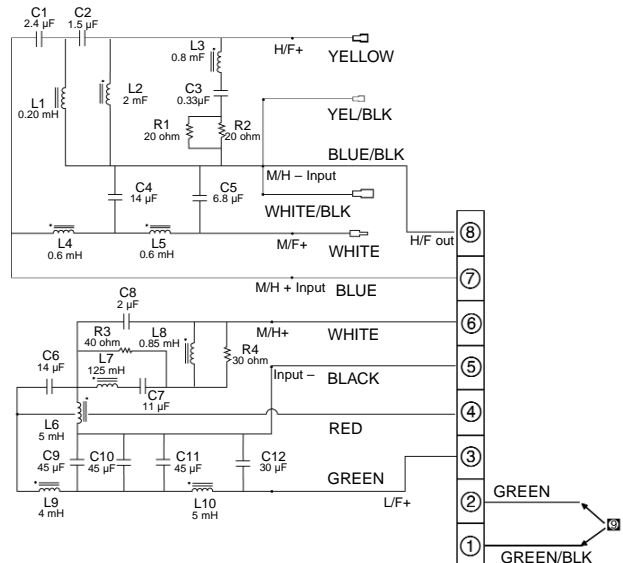

JBL AM4315/64-WH REV AA

