

Technical Manual



JBL AM4212/00-WH

SPECIFICATIONS

ACOUSTIC & ELECTRICAL SPECIFICATIONS:

- Nominal Impedance: 8 Ohms
- Power Capacity (AES): L.F. 400W (2000W Peak), 2 Hrs
300W (1200W Peak), 100 Hrs
H.F. 35W (140W Peak), 2 Hrs
- Frequency Range: 55 Hz – 20 kHz (-10dB)
- Sensitivity: L.F. 95dB SPL (1 W at 1 M)
H.F. 110dB SPL (1 W at 1 M)
- Crossover Frequencies: 4th Order (24dB/oct) Linkwitz-Riley
HP & LP, 1.3 kHz

SYSTEM COMPONENTS:

- Cabinet: Enclosure (Not For Sale)
- Grille: 338163-007, 338163-107 (WH)
- Low Frequency Transducer: 2023H, 300mm (12 in.) Driver With
75mm (3 in.) voice coil
- DC Resistance: 5.3 ohm ±10%
- High Frequency Transducer: 2407H, 38mm (1.5 in.) Exit Compression
Driver, 38mm (1.5 in.) voice coil

SYSTEM COMPONENTS: (CONT'D)

- DC Resistance: 4.25 ohm ±10%
- Crossover Network: 339441-001

AURAL SWEEP TEST SPECIFICATIONS:

- A. System Aural Sweep Test: 7.0V Input, 20 Hz to 20 kHz
- B. L.F. Aural Sweep Test: 7.0V Input, 20 Hz to 5 kHz
- C. H.F. Aural Sweep Test: 2.83V Input, 800 Hz to 20 kHz

PHYSICAL SPECIFICATIONS:

- Enclosure Dimensions: 713 x 371 x 460 mm D
(28.1 x 14.6 x 18.1 in.D.)
- Net Weight: 56 lb (25.4 kg.)

WARRANTY INFORMATION:

- Refer to Warranty Statement packed with each product.

PACKAGE

Warranty 59660
Installation Sheet
339390-032

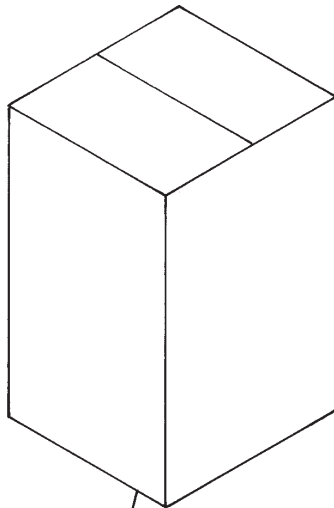

Carton
352188-001

Filler (2)
352187-001

Logo Sticker, Grille Assy (Small) AE
339397-001

Sticker, JBL
337638-001

Micro Foam (8)
49790P

Hardware Kit
229-00009-01

ACC, Not Included

WIRING DIAGRAM

Driver, Low Freq
2023H
(337215-001X)
Cone Repl
C8R2023

Driver, High Freq
2407H
(339150-001)
Diaph Repl
D8R2407

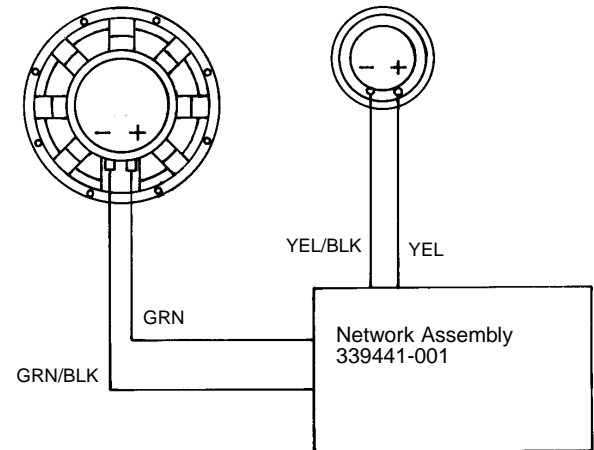

SEE NETWORK SCHEMATIC PAGE

NOTE: INDIVIDUAL PARTS FOR THE ABOVE CROSSOVER ARE NOT AVAILABLE.
A COMPLETE REPLACEMENT ASSEMBLY SHOULD BE ORDERED.

JBL AM4212/00-WH

COMPONENT EXPLODED VIEW

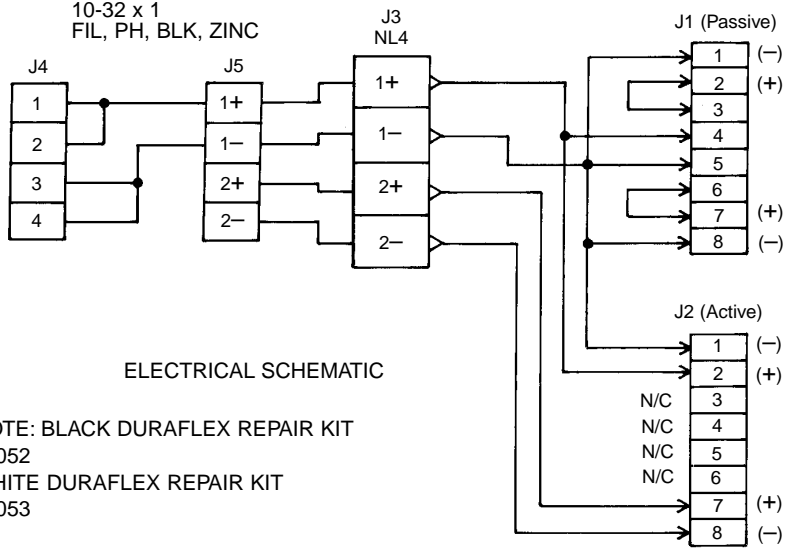
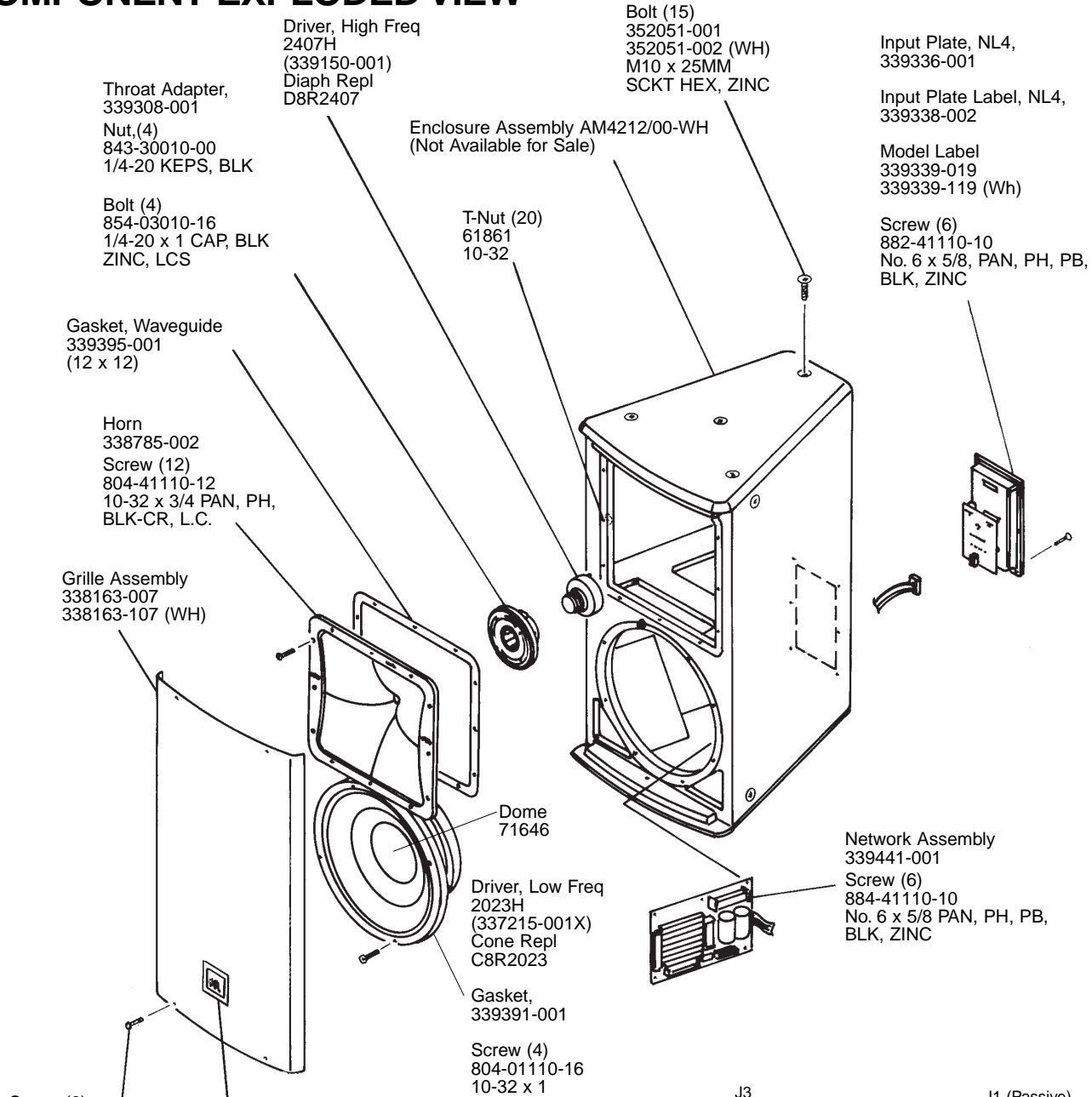

JBL AM4212/00-WH