

Technical Manual



JBL AM4200/95-WH

SPECIFICATIONS

ACOUSTIC & ELECTRICAL SPECIFICATIONS:

- Nominal Impedance: 8 Ohms
- Power Capacity: 150W
- Frequency Range: 350 Hz – 23 kHz (– 10 dB)
- Sensitivity: 106 dB, 1 watt @ 1 meter
- Crossover Frequencies: 2.8kHz

SYSTEM COMPONENTS:

- Cabinet: Enclosure (Not for Sale)
Right/Left Panel (338797-001),
Rear Panel (338796-001), Top/Bottom
Panels (338378-001)
- Grille Assembly: 338163-009, 338163-109 (WH)
- Mid Frequency Transducer: 165H, Cone Mid Range Compression
Driver with integral 165 mm (6.5 in)
diameter internal driver
- DC Resistance: 5.8 ohms ±10%
- High Frequency Transducer: 2407H, 38 mm (1.5 in.) Exit
Compression Driver, 38 mm (1.5 in)

SYSTEM COMPONENTS (CONT'D):

- DC Resistance: voice coil
4.3 ohms ±10%
- Network Assembly: 339435-002

AURAL SWEEP TEST SPECIFICATIONS:

- A. System Aural Sweep Test: 5.0VRMS Input, 100 Hz to 16 kHz
- B. M.F. Aural Sweep Test: 5.0VRMS Input, 100 Hz to 5 kHz
- C. H.F. Aural Sweep Test: 2.83VRMS Input, 1.6 kHz to 16 kHz

PHYSICAL SPECIFICATIONS:

- Enclosure Dimensions: 548 x 561 x 657 mm D
(21.6 x 22.1 x 25.9 in.D.)
- Shipping Weight: 61 lb. (27.7 kg.)

WARRANTY INFORMATION:

- Refer to Warranty Statement packed with each product.

PACKAGE

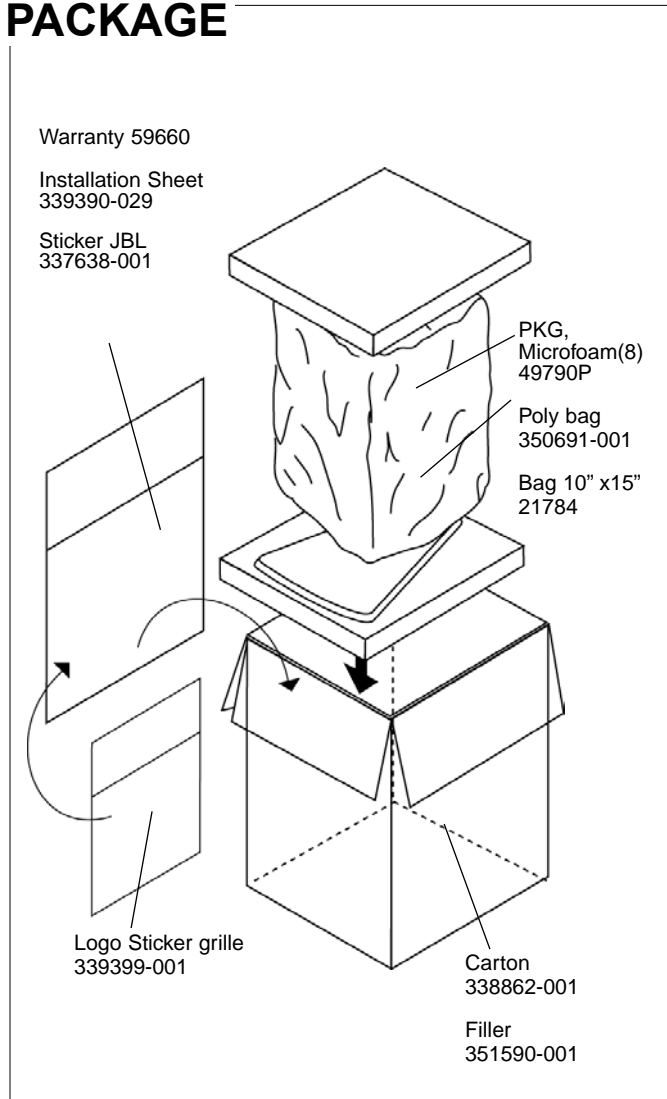

WIRING DIAGRAM

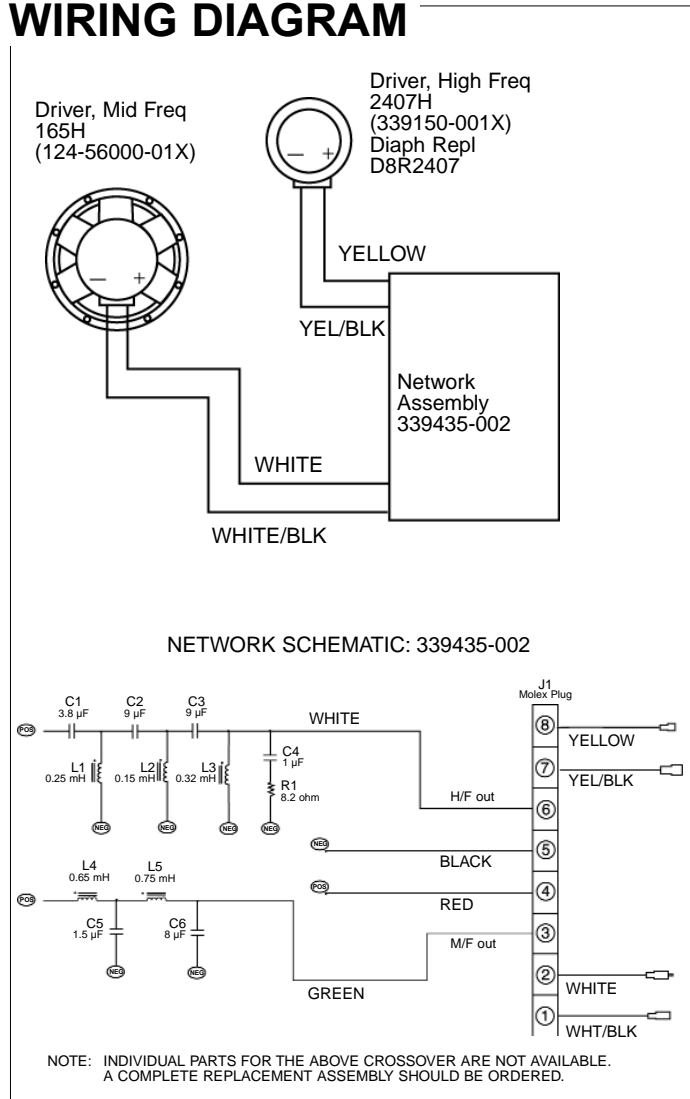

JBL AM4200/95-WH REV R

JBL AM4200/95-WH

COMPONENT EXPLODED VIEW

Enclosure Assembly
AM4200/95-WH
(Not Available for Sale)

Bolt (13)
Top/Bottom, Rear,
Right & Left
352051-001 (BLK)
352051-002 (WH)
M10x 25MM
SCKT, HEX,
ZINC

Model Label
339339-026
339339-126 (Wh)

Input Plate
339336-001

Input Plate Label
339338-002

Screw (12)
882-411110-10
6 X 5/8
PAN PH PB
BLK ZINC

Enclosure:
Rear Panel
338797-001

Mounting
Support 90° (6)
381-00023-01

Mounting
Bracket (1)
338652-001

Baffle
338798-001

T-Nut 10-32
(16)
61861

Wire Assbly.
350574-001

Rubber Gromet
333050-002

Screws (14)
883-411110-08

8-32 X .5
PAH, PH, PB,
BLK

Waveguide
350412-001

Screw (8)
882-511110-12
882-51160-12
(Wh)
6 X 3/4
OV, PH, PTCL,
LCS

Bolt (4)
854-03010-16
1/4-20 x 1
CAP, BLK,
ZINC

Locknut 1/4-20
834-30010-00

Throat
Adapter
339308-001

Screws (20)
804-411110-12
10-32 x 3/4

Gasket Can Front
339433-001

Rear Can
165H
339173-001

Gasket Can
Rear 165H
350239-001

Mid-Range 165H
124-56000-01X

Phasing Plug Gasket
339432-001

Network Assembly
339435-002

Enclosure:
Right /Left Panel (2)
338349-001

Washer #10 (4)
843-00110-06

Gasket 2250HPL
339403-001

Screws (4)
804-851110-16
#10-32 3/4

Phasing Plug
CMCD-61
339144-001

Screen Midrange
Phase Plug
339484-001

Support Block,
Grille (2)
338380-001

Enclosure:
Top/Bottom Panel
(2)
338378-001

Logo Grille
339400-001
339400-002 (WH)

Push Nut
350689-001
7/16

Compression Spring
35069-001

Washer
76168
.175ID ,750D

Grille Assembly
338163-009
338163-109 (WH)

Grille Support
338350-001

NOTE: BLACK DURAFLEX REPAIR KIT
30052
WHITE DURAFLEX REPAIR KIT
30053

JBL AM4200/95-WH